

OPERATOR'S MANUAL

FC748EP TRUCK MOUNTED LINE PUMP



INTRODUCTION

Congratulations on your purchase of a new Flowcrete pumping module.

Flowcrete's goal is to supply internationally and locally competitive concrete pumping modules. To achieve this, our range of concrete pumps have been designed for optimum performance with continual development in areas of manufacturing, new materials and design.

Your purchase is an investment to you. The employees of Flowcrete are conscious of the quality and reliability that accompanies this.

We recommend that you read this manual as you will be able to fully utilise all the features of your new pumping module.

To ensure the highest level of reliability, we suggest you follow our indicated maintenance schedule.

On behalf of Flowcrete and all its employees, I would like to thank you for buying a **Flowcrete** pumping module and wish you unlimited hours of concrete pumping.

BRIEF DESCRIPTION OF OPERATION

The Flowcrete is a concrete piston pump hydraulically powered either by diesel or electric prime mover. It pumps concrete by drawing from a hopper and filling a cylinder. When the cylinder is retracted and full of concrete, the piston using hydraulic force, extends and discharges the concrete through the swinger tube into the pipeline and out to the job.

The pump assembly is a twin piston pump with concrete rams mounted side by side. The concrete piston fits into two hard chromium plated cylinders which are connected to the back of the concrete hopper.

The twin pistons, stroke by reciprocating to each other, ie; when one cylinder is retracting (sucking concrete), the other is on the discharge stroke and pumping concrete out.

When both pistons are at each end of their sequence stroke, ie: on completely back and the other completely forward the swinger tube in the hopper pivots over to connect the other cylinder and immediately both pistons repeat the sequence.

The swinger tube connects the pumping cylinders to the pipeline and it swings over each time when pistons reach the end of their stroke. The speed of change over produces an almost continuous flow of concrete into the pipeline. The sequence of the swinger tube can be reversed in relationship to the pumping cylinder to give a sucking action on the pipeline to relieve any stored pressure if a blockage occurs.

FC748EP TRUCK MOUNTED

Swing Tube Valve Design
Hard Chromed Concrete Cylinders
Hydraulic Oil Cooler
PTO Powered
Control Panel with Pressure Gauges

Open Loop Hydraulic System

Pump Output Capacity	:	60 cubic metres per hour
Strokes per Minute	:	33
Concrete Line Pressure	:	45 BAR
Main Ram Hydraulic Pressure	:	200 BAR
Concrete Cylinders	:	180mm
Stroke Length	:	1200mm
Oil Tank	:	300 litres
Outlet Diameter	:	150mm
Water Tank	:	400 litres

WARNING

This machine which is known as a concrete pump is capable of producing high pressure in the delivery line. The operation should always be treated with extreme caution.

The operator should thoroughly read this technical manual and fully understand the machine operation procedures and the dangers of pressures the machine can produce. Once the machine has been run, there is stored pressure in the accumulator. At no time should any work be carried out on the machine until all pressure had been removed.

The delivery line must be checked regularly to determine it is capable of withstanding the pressures the machine can produce.

Note: Local pumping association requirements for delivery lines (see references).

WARRANTY

- 1.1 Flowcrete's liability for the equipment manufactured by it is limited to making good any defects by repairing the defects or at Flowcrete's option by replacement or payment of the repair by other persons, for a period not exceeding **one (1) year or Ten Thousand cubic metres** of concrete pumped, whichever first occurs, after the equipment has been delivered so long as:
 - 1.1.1 defects have arisen solely from faulty materials or workmanship;
 - 1.1.2 the equipment has not received maltreatment, inattention or interference;
 - 1.1.3 accessories of any kind used by the Buyer are manufactured by or approved by Flowcrete;
 - 1.1.4 the seals of any kind on the equipment remain unbroken;
 - 1.1.5 the defective parts are promptly returned free of cost to Flowcrete; and
 - 1.1.6 the equipment has been serviced.
- 1.2 Flowcrete is not liable to replace or carry out repairs to wear components nor for fittings or parts which may ordinarily work loose during the normal operation of pumping concrete and/or which require daily adjustment or checking.
- 1.3 If any part of the equipment is not manufactured by Flowcrete the guarantee of the manufacturer of that part of the equipment is accepted by the Buyer and is the only guarantee given to the Buyer in respect of that equipment. Flowcrete agrees to assign to the Buyer on request made by the Buyer the benefit of any warranty or entitlement to the equipment that the manufacturer has granted to Flowcrete under any contract or by implication or operation of law to the extent that the benefit of any warranty or entitlement is assignable.
- 1.4 Flowcrete is not liable for and the Buyer releases Flowcrete from any claims in respect of faulty or defective design of any equipment supplied unless such design has been wholly prepared by Flowcrete or the responsibility for any claim has been specifically accepted by Flowcrete in writing. In any event Flowcrete's liability under this paragraph is limited strictly to the replacement of defective parts in accordance with paragraph 7.1 of these conditions.
- 1.5 Except as provided in these conditions and unless prohibited by statute, all express and implied warranties, guarantees and conditions under statute or general law as to merchantability, description, quality, suitability or fitness of the equipment for any purpose or as to design, assembly, installation, materials or workmanship or otherwise are expressly excluded. Flowcrete is not liable for physical or financial injury, loss or damage or for consequential loss or damage of any kind arising out of the supply, layout, assembly, manufacture, installation or operation of the equipment or arising out of Flowcrete's negligence or in any way whatsoever.
- 1.6 In the event that the Trade Practices Act, 1974 applies to this Contract then Flowcrete's liability for a breach of a condition or warranty implied by Division 2 of Pt V of the Trade Practices Act 1974 (other than s 69) is limited to any one or more of the following:
 - 1.6.1 the replacement of the equipment or the supply of equivalent equipment;
 - 1.6.2 the repair of the equipment;
 - 1.6.3 the payment of the cost of replacing the equipment or of acquiring equivalent equipment;
 - 1.6.4 the payment of the cost of having the equipment repaired.
 - (i) Flowcrete's liability under s 74H of the Trade Practices Act 1974 is expressly limited to a liability to pay to the purchaser an amount equal to:
 - 1.6.5 the cost of replacing the equipment;
 - 1.6.6 the cost of obtaining equivalent equipment; or
 - 1.6.7 the cost of having the equipment repaired, whichever is the lowest amount.

Contents

INTRODUCTION	8
BRIEF DESCRIPTION OF OPERATION.....	8
WARNING.....	9
WARRANTY.....	10
SECTION 1: SAFETY INSTRUCTIONS & RISK MANAGEMENT	12
2. PIPELINE.....	45
2.2. PUMP LOCATION AND PIPELINE LAYOUT	45
2.3. PIPELINE SET-UP.....	45
3. PUMPING CONCRETE	46
3.1. INITIAL PUMP PREPARATION	46
3.2. PUMP START UP PROCEDURE.....	46
3.3. CONTROL PANEL OPERATION	47
3.4. SLURRYING UP	47
3.5. BLOCKAGE	48
PUMPABLE CONCRETE.....	49
GUIDE OR SIMPLE QUICK REFERENCE.....	51
ADMIXTURES.....	53
4. MAINTENANCE.....	54
4.1 MAINTENANCE	54
4.2 POST COMMISSIONING / FOLLOW-UP MAINTENANCE	55
4.3 DAILY/WEEKLY/MOHTLY MAINTENANCE.....	56
4.4 HYDRAULIC OIL.....	57
4.5 TROUBLE SHOOTING	57
4.6 PRESSURE ADJUSTMENTS	58
4.7 RECOMMENDED SPARE PARTS.....	59
FC748E Main Ram Assy	59
FC748E Hopper Assy.....	59
FC748E Hopper Door Assy	59
FC748E Swinger Ram Assy	59
FC748E Electrical Drawing.....	59
HOPPER ASSY DRAWING	61
Hydraulic Circuit Drawing -.....	66
FC748EP Hydraulic Circuit – Parts Listing.....	67
TYPICAL LAYOUT OF 24V FC748EP CONTROL PANEL.....	68
TYPICAL LAYOUT OF 24V FC748EP HYDRAULIC MANIFOLD.....	69
FC748EP OIL TANK & PROXIMITY SENSOR PARTS	70

SECTION 1: SAFETY INSTRUCTIONS & RISK MANAGEMENT

What is concrete pumping?

Concrete pumping is the transportation of a freshly mixed batch of concrete via a system of pipes to a specific location on a construction site. Concrete pumping is a widely used process in the construction industry. It can be used to manufacture pre-cast and tilt up concrete panels, concrete formwork, slab construction, concrete paving and concrete spraying.

Equipment used in concrete pumping includes the following:

Line Pump: Use of a fixed or mobile pump that pumps concrete through pipes and/or flexible hoses that run along the ground

Mobile Concrete Placing Boom: Use of a truck-mounted pump to pump concrete through pipework that is supported by a multi-staged boom

Satellite Concrete Placing Boom: Use of a fixed or trailer-mounted pump to pump concrete through pipework to a concrete placing boom fixed to the structure being built

Concrete is normally delivered to the concrete pump using a concrete truck that dispenses concrete into the hopper on the pump, which is then pushed through pipework to the location of the concrete pour. Concrete pumping is generally a more efficient means of delivering concrete in comparison to the use of a wheelbarrow or crane-lifted concrete kibble.

However, due to the high pressure involved and the pulsating motion of the pump, there can be significant safety risks associated with pumping concrete.

Generally, concrete pumping work is defined as construction work. It may also be considered high risk construction work under the Work Health and Safety (WHS) Regulations. A safe work method statement (SWMS) must be prepared before high risk construction work starts.

Who should use this guide?

This guide provides practical guidance to assist duty holders, primarily a person conducting a business or undertaking (PCBU), to manage risks to health and safety associated with concrete pumping in construction work. You should use this guide if you own, hire, lease, handle, store, transport, maintain or use concrete pumping equipment in the workplace.

How to use this guide

This Guide is intended to supplement other information produced by Safe Work Australia to assist you to meet your duties and obligations under WHS laws. It should be read in conjunction with the following:

- [Model Code of Practice: How to manage work health and safety risks](#)
- [Model Code of Practice: Managing the risks of plant in the workplace](#), and
- [Model Code of Practice: Construction work](#).

This Guide includes references to the legal requirements under the WHS Act and WHS Regulations. These are included for convenience only and should not be relied on in place of the full text of the WHS Act or WHS Regulations.

In this Guide, the word 'must' indicate a legal requirement that must be complied with. The word 'should' indicate a recommended course of action.

Who has health and safety duties?

Everyone at the workplace involved in concrete pumping has health and safety duties. A person can have more than one duty and more than one person can have the same duty at the same time.

Persons conducting a business or undertaking

WHS Act section

19 Primary duty of

care **WHS Act**

section 21

Duty of persons conducting businesses or undertakings involving management or control of fixtures, fittings or plant at workplaces

PCBUs have the primary duty of care for the health and safety of their workers and others at the workplace.

A PCBU can be a:

- 1.1. company
- 1.2. unincorporated body or association
- 1.3. sole trader, or
- 1.4. self-employed person.

Individuals who are in a partnership that is conducting a business or undertaking will individually and collectively be a PCBU.

A PCBU must ensure, so far as is reasonably practicable, that workers and other people are not exposed to health and safety risks arising from the business or undertaking.

This duty requires the person to manage risks by eliminating health and safety risks so far as reasonably practicable, and if it is not reasonably practicable to eliminate the risks, by minimising those risks so far as is reasonably practicable.

It also includes ensuring so far as is reasonably practicable the:

- 1.1. provision and maintenance of safe plant, including concrete pumping equipment, and
- 1.2. safe use, handling, storage and transport of plant.

A PCBU also has a number of more specific obligations, which are set out in the WHS Regulations.

Principal contractors

WHS Regulations 308-315

Duties of principal contractors

Projects involving construction work which costs \$250,000 or more are classified as 'construction projects' under the model WHS laws. Each construction project has a 'principal contractor'. A principal contractor is also a PCBU. The principal contractor

for a construction project is:

- 1.1. the PCBU that commissions a construction project
- 1.2. if the PCBU that commissions the project engages another PCBU to be the principal contractor and authorises the person to have management or control of the workplace and to discharge the duties of the principal contractor, the PCBU so engaged, or
- 1.3. if the owner of residential premises is an individual who directly or indirectly engaged a PCBU to undertake a construction project in relation to the premises, the PCBU so engaged, provided the PCBU has management or control of the workplace.

A construction project only has one principal contractor at any specific time.

In addition to the duties imposed on a principal contractor as a PCBU, the principal contractor has duties relating to WHS management plans, ensuring general compliance, and managing specific risks.

Designers, manufacturers, importers, suppliers and installers

WHS Act section 22

Duties of persons conducting businesses or undertakings that design plant, substances or structures

WHS Act section 23

Duties of persons conducting businesses or undertakings that manufacture plant, substances or structures

WHS Act section 24

Duties of persons conducting businesses or undertakings that import plant, substances or structures

WHS Act section 25

Duties of persons conducting businesses or undertakings that supply plant, substances or structures

WHS Act section 26

Duties of persons conducting businesses or undertakings that install, construct or commission plant or structures

WHS Regulation 295

Designers must give safety report to person who commissions design

A designer, manufacturer, importer, supplier or installer of concrete pumping equipment must ensure, so far as is reasonably practicable, that the concrete pumping equipment they design, manufacture, import, supply or install is without risks to health and safety. This includes undertaking necessary associated testing and providing adequate information about the concrete pumping equipment. Suppliers must provide a purchaser of concrete placing booms with the design registration number.

When hiring or leasing concrete pumping equipment, the person who owns the equipment must be consulted about potential hazards, as there is a shared responsibility for ensuring, so far as is reasonably practicable, that the equipment is safe to use and without risk to health and safety.

Anyone hiring or leasing concrete pumping equipment to others has duties as both a supplier of the equipment and as a person with management or control of the equipment at the workplace. They must check the equipment is safe to use and properly maintained and provide specific information including safe operation instructions.

Officers

WHS Act section 27

Duties of officers

An officer (for example a company director) must exercise due diligence to ensure the PCBU complies with the WHS Act and WHS Regulations. This includes taking reasonable steps to ensure the PCBU has and uses appropriate resources and processes to eliminate or minimise risks to health and safety.

Workers

WHS Act section 28

Duties of workers

If not used correctly, concrete pumping equipment can be dangerous to workers and others. Workers have a duty to take reasonable care for their own health and safety, and to take reasonable care to not adversely affect the health and safety of other persons.

Workers must also:

- 1.1. comply as far as they are reasonably able with any reasonable WHS instructions from the PCBU such as wearing relevant personal protective equipment (PPE), and
- 1.2. co-operate with any reasonable policy or procedure relating to WHS at the workplace that has been provided to them.

The PCBU must make workers aware of the hazards associated with the use of concrete pumping equipment, including the process for reporting safety incidents.

When discussing health and safety matters with workers, a consultative approach should be taken to allow workers a reasonable opportunity to express views before any decision is made.

Other persons at the workplace

WHS Act section 29

Duties of other persons at the work place

Other persons at the workplace, such as visitors, must take reasonable care for their own health and safety and must take reasonable care not to adversely affect other people's health and safety. They must comply, so far as they are reasonably able, with reasonable instructions given by the PCBU to allow that person to comply with the WHS Act. If PPE is provided by the business or undertaking, other persons at the workplace must, so far as they are reasonably able, use or wear it in accordance with the information, instruction and training provided.

WHS laws in your state or territory

The Commonwealth, state and territory WHS regulators are responsible for enforcing WHS laws. They make decisions about whether you are in compliance with the requirements.

WHS laws are not the same across Australia. If you need help understanding your WHS requirements, please contact your [WHS regulator](#).

Further information on work health and safety duties is in the [model Code of Practice: *Managing the risks of plant in the workplace*](#) and the [model Code of Practice: *How to manage work health and safety risks*](#).

Managing health and safety risks

As a PCBU, you must manage the health and safety risks associated with concrete pumping in the workplace. In concrete pumping operations, risks may arise from known hazards including, but not limited to:

- Plant and equipment, including:
 - concrete placing booms
 - pump gauges
 - concrete pipelines
 - pipe clamps
 - anchor brackets
 - pipes
 - delivery hoses
 - receiving hoppers
 - outriggers
- Placement of plant and equipment, for example:
 - proximity to traffic, members of the public, powerlines, other plant, structures and trenches
 - ground stability
- Tasks, including:
 - concrete delivery
 - pump and boom operation
 - concrete pipeline handling, erection and dismantling
 - concrete pouring
 - pump relocation (internal climbing)
 - line cleaning
 - pump cleaning
 - road travel
- By-products, such as fumes, dust and noise.

This document discusses the hazards and risks listed above, including appropriate control measures.

Consultation

You must consult, so far as is reasonably practicable, with your workers and their elected health and safety representatives (if any) about health and safety at your workplace.

Workers must be consulted on health and safety matters, including (but not limited to):

- identifying hazards and risks associated with the use of concrete pumping equipment
- making changes to processes or procedures
- improving controls put in place to protect workers from the identified risks
- procedures for resolving health and safety issues
- procedures for monitoring the conditions at the workplace, and
- procedures for providing information and training.

Participation of your workers in discussions about health and safety is important, as they are most likely to know about the risks of their work. Joint involvement in identifying hazards and

assessing and controlling workplace risks will help build a mutual commitment to this process and any changes that may result.

Further information on consultation requirements is in the [Code of Practice: Work health and safety consultation, co-operation and co-ordination](#).

The risk management process

Risk management requires you to think about what could go wrong at your workplace and what the consequences could be. Then you must do whatever is reasonably practicable to eliminate or minimise those risks.

Risk management involves four steps:

- **Identify hazards**—find out what could cause harm.
- **Assess risks, if necessary**—understand the nature of the harm that could be caused by the hazard, how serious the harm could be and the likelihood of it happening. This step may not be necessary if you are dealing with a known risk with known control measures.
- **Control risks**—work through the hierarchy of risk controls to implement the most effective control measure that is reasonably practicable in the circumstances and ensure it remains effective over time.
- **Review hazards and control measures** to ensure they are working as planned.

Determining what control measures are reasonably practicable includes consideration of the availability and suitability of control measures. Cost may also be relevant, but you must only consider this after you have assessed the extent of the risk and the available ways to eliminate or minimise the risk.

Further information on the risk management process is in the [Code of Practice: How to manage work health and safety risks](#).

Identify the hazards

The first step in the risk management process is to identify hazards associated with concrete pumping. Identifying hazards involves finding things and situations that could potentially cause harm to people.

There are many hazards associated with concrete pumping that can pose a risk to the health and safety of workers.

The following can help you identify hazards:

- Observe the workplace. Consider the ground conditions where the pumping equipment will operate and how it could interact with other plant, people and structures, including overhead electric lines. Think about the layout of your workplace and the placement of any overhead structures where the concrete placing boom may be used.
- Review inspection, test and maintenance records, such as log books and incident and injury records, including near misses.
- Consult with other PCBU's, concrete pumping operators, workers, and others about specific hazards and any problems they encounter. This could include problems with operation, inspection, maintenance, repair, transport and storage of concrete pumping equipment.

Hazards can also arise from the conditions of the workplace. For example, local weather conditions can introduce new hazards. High winds can be dangerous and cause uncontrolled movement of a concrete placing boom. Rainfall can affect ground conditions which may cause the machine to become unstable. Operating in storms risks lightning strikes to booms.

Assess the risks

Even though the risks and related control measures will be known in many cases, you should carry out a risk assessment. Risk assessments help determine how serious the risk posed by the hazard is, what action is necessary to control the risk, how urgently the action needs to be taken and who is responsible for implementing the control measure.

A risk assessment should be carried out if any of the following apply:

- there is uncertainty about how a hazard may result in an injury
- the work activity involves a number of different hazards, or
- there is any lack of understanding of how these hazards may interact with each other.

Risk assessments should consider:

- the effectiveness of existing control measures
- how work is actually undertaken in the workplace (compared to the written manuals and procedures and infrequent or abnormal situations)
- maintenance and cleaning
- breakdowns of equipment, and
- failures of health and safety controls.

The assessment should also:

- identify the type and potential severity of the harm (*Note:* other factors, such as the potential distance of a fall, may influence the severity)
- consider the number of people potentially exposed to the hazard
- work out the likelihood of harm occurring, and
- consider how frequently the task is done or how close people are to a hazard.

Take action to control the risks

WHS laws require you to do everything reasonably practicable to eliminate or minimise risks to health and safety in the workplace. It is most likely you will need to use a range of control measures to protect your workers from the risks associated with concrete pumping.

Controlling risks should involve discussing site-specific requirements, including the concrete pump selection, concrete delivery and traffic control requirements.

The ways of controlling risks are ranked from the highest to lowest level of protection and reliability, known as the hierarchy of risk controls. You must work through this hierarchy to manage risks.

You must always aim to eliminate a risk where reasonably practicable. Where a risk cannot be eliminated, it must be minimised, so far as is reasonably practicable, using one or more of the following approaches:

- substitution
- isolation, and
- engineering controls.

If the risk cannot be completely managed by the above controls, the remaining risk must be further minimised using administrative control measures, so far as is reasonably practicable. If risk remains thereafter, personal protective equipment (PPE) should be used to control any remaining risks. Cost may also be relevant, but you can only consider this after an effective review of all reasonably practicable control measures. A control measure can only be discounted where the cost of implementing the control is grossly disproportionate to the risk.

A combination of control measures may be required where a single control is not sufficient to minimise the risks. Monitor and review all controls to ensure they remain effective.

Elimination

The first thing you must consider is whether a risk can be completely removed from the workplace. For example, for small jobs it may be possible to move concrete using wheelbarrows to eliminate the need to use concrete pumping equipment.

If it is not reasonably practicable to completely eliminate the risk, then risks must be minimised, so far as is reasonably practicable, using the hierarchy of controls.

Substitution controls

Substituting the hazard for something safer can be an effective control measure. For instance, if working in an area with overhead structures or limited space, you may be able to substitute a concrete placing boom with a line pump to minimise risks.

Isolation controls

Isolation involves physically separating the source of harm from people. For example, if the concrete placing boom is close to a deep excavation, use physical barriers, such as secured fencing, to ensure persons and plant cannot access the excavation edge or unstable ground near the excavation edge.

Engineering controls

An engineering control is a control measure that is physical in nature, including a mechanical device or process. These are permanent or automatically applied and do not rely on human behaviour to be effective. For example, the use of a hopper with 'low level' sensors to indicate when the concrete levels are low and likely to pull air in with the mix.

Administrative controls

If risks remain after implementing all reasonably practicable substitution, isolation or engineering controls, they should be minimised by implementing administrative control measures, so far as is reasonably practicable. Administrative control measures include work methods or procedures that are designed to minimise exposure to a hazard as well as the information, training and instruction needed to ensure workers can work safely.

Administrative controls are less effective than other control measures because they do not control the hazard at the source and instead rely on human behaviour and supervision.

Some administrative measures will be necessary to ensure substitution, isolation and engineering control measures are implemented effectively, for example, following safe work procedures when using equipment.

Personal Protective Equipment

Personal protective equipment (PPE) is the least effective method for controlling risk in isolation, however it can be effectively used in conjunction with higher level controls to minimise residual risk. Before beginning any pumping operation, you and the principal contractor or person in control of the workplace should assess the conditions likely to affect the health and safety of workers and arrange for the provision and use of appropriate PPE. You must provide the PPE required to manage the risks and ensure workers are trained in its correct use.

The following items of PPE may be required when pumping concrete:

- safety helmets
- eye protection
- face masks
- safety vests, and
- rubber safety boots.

The following may also be required:

- hearing protection, and
- gloves.

Maintain and review control measures

You should regularly review control measures to make sure they remain effective. This is particularly important if there have been changes to the nature or duration of work.

Consulting with workers and their representatives, if any, can help determine if the control measures are effective. You should also consider:

- if the control measures introduce any new risks
- if the workers are actively involved in identifying hazards or controls
- if incidents are occurring more or less frequently, and
- if any new information or equipment has been developed that may be effective.

If issues with the controls are found, the risk management process should be repeated to identify additional ways to effectively manage the risks.

Information, training, instruction and supervision

You must, so far as is reasonably practicable, provide any information, instruction,

training or supervision necessary to protect people from health and safety risks that arise from the work carried out as part of the business or undertaking.

You must ensure that information, training or instruction provided to a worker is suitable and adequate for:

- the nature of the work carried out by the worker
- the nature of the risks associated with the work at the time of the information, training and instruction, and
- the control measures implemented.

You must also ensure, so far as is reasonably practicable, that the information, training and instruction are provided in a way that is readily understandable for the person to whom it is provided.

Information, training and instruction provided to workers should include:

- familiarization with new or unfamiliar plant and work environments
- communication procedures between the concrete pump operators, ground workers and any other relevant workers
- relevant information for operators, including how to operate the equipment correctly, how to conduct pre-operational inspections and safe use of the pump
- the proper use, wearing, storage and maintenance of PPE
- the hazards and risks associated with the work performed
- how to follow the health and safety procedures associated with the work, including the contents of any SWMS for high-risk construction work
- emergency and rescue procedures, including how to position equipment to ensure access to emergency controls is not obstructed
- procedures for reporting hazards and incidents, and
- control measures for other potential hazards, such as unstable ground.

Those supervising the work should also receive training. The amount and type of training required will depend on the nature of the work and the risks involved.

You must not direct or allow a worker to carry out construction work unless the worker has successfully completed general construction induction training and has carried out construction work in the last two years, if the worker completed training more than two years previously. You must also ensure the worker holds a general construction induction training card or a general construction induction training certification issued within the preceding 60 days.

For further information on induction training, see the information sheet: [Workplace induction for construction workplaces.](#)

Relevant competencies

Concrete pump and boom operators must be competent to safely operate the relevant equipment. Competency is achieved through training and supervision and should be assessed by testing both theoretical knowledge and physical operation of the equipment. Anyone operating a concrete placing boom must hold the relevant high risk work licence.

Pump and boom operators should:

- be familiar with and operate the plant in line with manufacturer's (or competent person's) advice and information contained within manuals and other documents, including hydraulic pressure relief settings and maximum

rated concrete pressure

- carry out the daily maintenance inspection, visual inspection of the pipeline and other preoperational inspections in accordance with the manufacturer's instructions, before pumping commences
- ensure concrete pumping equipment is not left unattended while in operation
- pump concrete only when the hopper grate is in the closed position (grates should be interlocked to prevent this)
- ensure pump flow rates match discharge rates of concrete delivery trucks
- be able to maintain a volume of concrete in the concrete pump hopper at levels that will not allow air into the pump. The SWMS should include specifics of how this will be achieved (e.g. automatic shut-off if level of concrete in hopper falls too low; or additional competent person stationed at hopper to stop the pump)
- follow the directions of the line hand, and
- ensure a system of communication is maintained with the line hand.

Reporting defects

Pump operators should report defects immediately. If a defect is a hazard to safety, pumping operations should be stopped until the defect is rectified. Details of reported defects and subsequent action taken should be entered into a log book.

Licensing requirements

Under the WHS Regulations, a person operating a concrete placing boom must hold a high-risk work licence. Schedule 3 to the WHS Regulations identifies the classes of work that require a high-risk work licence. Operators of concrete placing booms must hold the high-risk work licence, Licence to operate a concrete placing boom. You must not ordinarily direct or allow a worker to carry out high risk work unless you have seen written evidence of the worker's high risk work licence. A person who operates a concrete placing boom is not required to be licensed if they are undertaking training to obtain their high-risk work licence and supervised by a person holding the relevant licence. A licence is also not required if the work carried out is:

- solely for manufacturing, testing, trialling, installing, commissioning, maintaining, servicing, repairing, altering or disposing of the concrete placing boom, or
- solely for the purpose of moving, loading or unloading the concrete placing boom in the workplace.

Emergency plans

You must ensure an emergency plan is prepared for each workplace where concrete pumping equipment will operate. You must ensure workers are trained and familiar with emergency and rescue procedures. The plan must be tested in the workplace and include emergency procedures like effective response, evacuation and notifying emergency services. Workers should know how to contact emergency services, with contact numbers easily accessible. Signs displaying evacuation locations should be placed where they can be easily seen. Rescue equipment should be available and easily accessible. There should be processes in place so that injured workers, including operator, can be rescued.

Planning and preparation for concrete pumping operations

Planning and preparation is the first step in ensuring that work is done safely. Planning for concrete pumping operations should start as early as possible in the

development of any work or project to help eliminate many of the associated health and safety risks. For planning to be successful, it should involve consultation with all people engaged in the work. This may include the principal contractor, any PCBUs, the electricity authority, designer, project manager, road authorities and operators of the plant.

4.1.1. Registering a concrete placing boom

Concrete placing booms must be registered with a WHS regulator before they can be used in the workplace. Concrete placing boom designs must be design registered before being supplied, and the plant must also be item registered before being commissioned for use. The concrete placing boom manufacturer or supplier must provide the design registration number with the plant.

The concrete placing boom design registration number must be readily accessible in the vicinity of the plant at all times. If a person modifies a concrete placing boom, they then take on the duties of a designer under WHS laws. They must ensure the modified plant is safe and the new design is design registered.

Pumping operation planning

Effective planning will help identify ways to protect people who are:

- directly involved in the concrete pumping work
- performing other work activities at the workplace, and
- the general public.

When planning concrete pumping operations, you should consider:

- liaising with electricity supply authorities regarding the safe supply of electricity and control measures for working around existing power supplies
- the proximity to overhead and underground powerlines, eliminating electrical risks if possible or using appropriate control measures to minimise risks, such as exclusion zones. The concrete placing boom manufacturer may specify instructions for operating near power lines which should be followed when planning concrete pumping operations
- concrete pumping requirements, including concrete pumping equipment selection, concrete delivery, ground conditions and site access, at the project design stage
- traffic control requirements
- ensuring that an emergency plan has been prepared for each workplace where concrete pumping work will be undertaken
- providing additional safety observers and spotters, depending on the size and complexity of the work
- ensuring plant is suitable for the work and minimises the risks of injury from movements such as hose whip
- maintaining adequate clearances between mobile plant (such as cranes, elevating work platforms, forklifts), mobile plant loads and concrete pumping equipment and ensuring you conduct negotiations between worksites, so you are able to maintain sufficient clearances when mobile plant and concrete pumping equipment operate on adjacent worksites and share the same airspace.

Before commencing concrete pumping operations, you should ensure that:

- people not involved in concrete pumping (workers and members of the public) are excluded from the work area
- if required, the spotter stays in view of the concrete truck driver while the truck is moving. If the spotter is out of the view of the truck driver, the driver is to stop the vehicle
- people in the concrete delivery area are wearing high visibility vests
- concrete trucks have audible reversing alarms and flashing amber lights
- permits have been obtained from the relevant authority where concrete pumps are setup on, or adjacent to, public roads
- the weather conditions are suitable for the pour, and
- any necessary barriers and signage are in place, no matter how brief the occupation of the site, for the:
 - protection of workers and the public
 - protection of the pipes and the pump
 - provision of adequate warning of changes in surface condition, and the presence of personnel or plant engaged in work on the road
 - adequate instruction of road users and their safe guidance through, around or past the worksite.

In addition, each pump unit should be equipped with the following items:

- first aid kit (including eye wash)
- fire extinguishers, and
- sufficient reflective traffic cones, signs (e.g. exclusion zone) and high visibility vests.

Safe work method statements

The WHS Regulations state that a SWMS is required for high-risk construction work. Some examples of high-risk construction work most likely to be applicable to concrete pumping include work carried out:

- in an area where there is any movement of mobile powered plant
- on, in or adjacent to a road, railway, shipping lane or other traffic corridor in use by traffic other than pedestrians
- in or near a shaft or trench deeper than 1.5 m or a tunnel, and
- near energised electrical installations or services

A SWMS is a written document that must identify the high-risk construction work activities to be carried out at a workplace, the hazards and risks to health and safety arising from these activities, the measures to be implemented to control the risks and how the control measures are to be implemented, monitored and reviewed.

Its primary purpose is to help PCBUs, supervisors and workers implement and monitor the control measures established at the workplace to ensure high risk construction work is carried out safely.

Who is responsible for preparing a SWMS?

As a PCBU, you must prepare a SWMS—or ensure a SWMS has been prepared—before high-risk construction work starts.

The person responsible for carrying out the high-risk construction work is best placed to prepare the SWMS, in consultation with workers who will be directly engaged in the work.

If more than one PCBU has the duty to ensure a SWMS is or has been prepared, they must consult and cooperate with each other to coordinate who will be responsible for actually preparing it.

There may be situations where there are different types of high-risk construction work occurring at the same workplace. In these cases, one SWMS may be prepared to cover all high-risk construction work activities. Alternatively, a separate SWMS can be prepared for each type of high-risk construction work. If separate SWMS are prepared, consider how the different work activities may impact on each other and whether this may lead to inconsistencies between control measures.

SWMS content

The content of a SWMS should provide clear direction on the control measures to be implemented.

SWMS must be accessible and understandable to any individual who needs to use it. It is important that those who need to carry out work in accordance with the SWMS understand the detail of the SWMS and what they are required to do to implement and maintain risk controls. For example, it should consider the literacy needs and the cultural or linguistically diverse backgrounds of workers.

Consultation

Workers and their health and safety representatives, if any, must be consulted so far as is reasonably practicable when preparing a SWMS. If there are no workers engaged at the planning stage, you must consult with workers when the SWMS is first made available, for example during workplace-specific training or a toolbox talk. You must also consult with workers and their health and safety representatives, if any, when a SWMS is reviewed.

Complying with a SWMS

If you are involved in high-risk construction work, you must put in place arrangements to ensure the work is carried out in accordance with the SWMS. The PCBU who directly engages the workers performing the high-risk construction work is best placed to implement the SWMS and to ensure compliance.

A principal contractor must have a system in place to monitor compliance with the SWMS.

If work is not being carried out in accordance with the SWMS then the work must stop immediately, or as soon as it is safe to do so. Work must not resume until it complies with the SWMS. If another method is identified as being a reasonably practicable option, you should revise the SWMS to take this into account before re-commencing work.

Concrete pumping equipment owner

The owner of concrete pumping equipment must take all reasonable steps to ensure that all safety features and warning devices of the plant are operational and used in accordance with the relevant instructions and training.

An owner who employs concrete pump operators should also ensure that operators have undergone appropriate training and that line hands are trained and competent.

The owner must ensure that all information obtained from the manufacturer of the concrete pumping equipment is supplied and readily available to those who need it (e.g. the concrete pumping equipment manufacturer's operating manual should be kept with the concrete pump, and maintenance staff should have access to all current maintenance manuals). The owner should ensure the design, maintenance records and all inspection reports for the plant are available and signed off before deployment.

Concrete pumping equipment operator

A concrete pump operator must always operate the concrete pumping equipment safely. Concrete operators are required to know:

- the model of plant to be operated, its characteristics, functions and limitations
- the information in the concrete pumping equipment's operating manual, and
- any site conditions that may affect concrete pump operations, including the presence of overhead powerlines and nearby structures and plant, for example cranes.

Before and during concrete pumping operations, the operator should:

- check unauthorised people are not present in the concrete pumping exclusion zone
- check each boom motion is safe and without risk
- complete the daily inspection checklist, including filling out the log book
- for mobile concrete placing booms, ensure outriggers are set according to the manufacturer's operating instructions for the specific type of mobile concrete pump
- monitor the safe use of the concrete pump, concrete delivery lines and boom (if fitted)

Note: In the case of satellite booms, the boom operator is responsible for the safe operation of the boom but will not be able to monitor the hopper – a separate pump operator located at the pump will perform this function. Likewise, the pump operator on a satellite boom installation is not able to monitor the safe operation of the concrete placing boom. In these cases, a reliable means of communication must be provided between the boom operator and pump operator.

- in the case of mobile concrete placing booms, periodically check outriggers or stabilisers for movement during operation
- be in view of the line hand and monitor the safe delivery of concrete, and
- monitor the concrete hopper.

Operators of concrete placing booms must hold the high-risk work licence, *Licence to operate a concrete placing boom*. Where the discharge hose needs to be moved, directed or held during the pour, the concrete pump operator is not to carry out the task of the line hand located at the end of the concrete delivery line.

Safe operation of concrete pumping equipment

Setting up on site

When setting up a concrete pump, the area should be level, capable of supporting

the load and free of obstructions. If it is not possible to set up the pump on level ground, ensure that the incline or angle of the machine does not exceed the manufacturer's recommendations.

If outriggers are required, you should ensure:

- adequate outrigger pads (e.g. timbers) for packing the base plate are supplied
- the outrigger pads are clear of excavations, soft or filled ground, or other obstacles
- the outrigger pads have sufficient bearing area to support the machine
- the outriggers are regularly checked to ensure stability, and
- the outriggers are adequately protected from inadvertent impact (e.g. from passing traffic).

Short legging is a practice that should be avoided wherever possible, due to the increased risk of overturning the pump.

Take particular care when a concrete pump is used in the vicinity of an excavation. The weight of the concrete pump, vibration and the load can affect the stability of the excavation wall and cause the excavation wall to collapse, which may lead to the concrete pump overturning. Do not position the pump over or adjacent to:

- previously disturbed ground that has been backfilled
- excavations, trenches or holes in the ground
- cellars, basements or pits, or
- inadequately compacted or soft ground.

The operator should immediately refer any concerns over the placement of the concrete pumping equipment (i.e. if it is on unstable ground or near an excavation) to the principal contractor.

Ensure unauthorised persons are kept away from the plant. Authorised persons working in the concrete pumping exclusion zone should wear high visibility vests.

The area should be clearly marked and made safe from other traffic, ensuring there is clear access for the safe movement of materials, equipment and persons. If concrete pumping activity is taking place on or near the access way, put in place a second access way.

Setup areas should also be provided with clear access and adequate lighting at all times during operation. Clearly post signage stating that the area is for authorised persons only.

Maintaining stability of concrete placing equipment

Ground factors

Ground conditions can vary dramatically from one workplace to another, and even within the one workplace. Ground conditions can affect the stability of concrete pumping equipment and may cause it to overturn and result in serious injury.

The following may affect ground stability:

- slope/gradient
- water (including mud and underground sources)
- the type of ground (e.g. clay, sand, rock)
- back-filled ground
- cavities or penetrations in the ground
- continued operation of the concrete pump in one location
- clearances to other services.

Wind loading

Do not operate mobile and satellite concrete placing booms in winds exceeding manufacturer's specifications. This information should be either on the manufacturer's identification plate on the unit or in the operating manual for the unit.

Role of a spotter

A spotter is a person who is trained and competent to observe and advise the pump/vehicle operators, if the vehicle or the pump is likely to contact a person, structure or moving plant on site.

The spotter should:

- have knowledge about working safely around moving plant, including the understanding of escape routes and maintaining visibility
- understand the relevant traffic management guidelines for the site, including any site-specific traffic management plan and SWMS
- understand exclusion zones, how the concrete pump operates and the limits of its range of movement, and
- understand the potential of the equipment to encroach on exclusion zones or contact people, structures, or plant.

Concrete delivery

The concrete delivery process poses risks to the concrete delivery truck driver, the concrete pump operator, the allocated spotter, other workers working in and around the concrete pumping exclusion zone and members of the public.

These risks include being hit or run-over by a delivery truck, or being trapped between the delivery truck and hopper or between delivery trucks. Risks also include entanglement, crushing and amputation from the concrete hopper and being struck by plant and other material.

A checklist for safely receiving concrete delivery and delivering it to the pump hopper is included in Appendix A & Appendix A.a

Concrete pumping

When pumping concrete, there may be a risk of concrete lines bursting, lines becoming unrestrained and pipe clamps being dislodged. Damage to delivery hose or the inappropriate selection of the delivery hose may also cause the discharge of concrete under pressure.

A checklist for minimising health and safety risks when pumping concrete is given in Appendix B.

Minimising the risk of hose whip

Hose whip is the term used to describe uncontrolled and rapid motion of the flexible rubberhose on the end of a concrete placing boom or other concrete delivery line. Hose whip is extremely dangerous and can occur during the concrete pumping operation itself or when the line is being cleaned out.

People can be seriously injured or killed by being struck directly by the whipping hose itself, being knocked over and hitting the ground or an object or being hit by ejected material.

A checklist for minimising the likelihood of injury from hose whip when operating concretepumping equipment is given in Appendix C.

Avoiding blockages

Concrete line blockages can be caused by mix design deficiencies, pipeline and joint deficiencies and excessive component wear in parts of the concrete pump. This is dangerous as blockages can cause segregation of the concrete mix, meaning components of the mix do not bind together and start to separate.

A checklist for minimising risks associated with concrete line blockages is provided in Appendix D.

Clearing blockages

The operator may be able to break an aggregate jam loose by alternately reversing the pump and resuming pumping a few times. Though a minor blockage can be cleared in this way, no amount of pressure will clear a major blockage. Do not continue the reversing process for more than a few attempts because it can make the blockage even tighter.

If reversing the pump does not work, an alternative method needs to be carried out to locate the blockage.

When attempting to clear a blocked concrete delivery line, follow the checklist provided in Appendix D to minimise risks to health and safety.

On-site line cleaning

Dislodged concrete and plugs used for cleaning can act as a high-velocity projectile, potentially striking both workers doing cleaning and others nearby. You should undertake and document risk assessments to effectively control the risks of line cleaning.

When performing line cleaning, follow the checklist given in Appendix E.

On-site pump cleaning

Entanglement, crushing, and amputation hazards exist in a concrete hopper and pumping device.

To minimise risks to health and safety when cleaning a pump on-site, follow the checklist provided in Appendix E.

Traffic control

Concrete pumping is often carried out in busy, trafficable areas. Motorists, cyclists, pedestrians, delivery truck drivers and workers may interact with concrete pumping equipment as it arrives and is set up in the designated concrete pumping area.

There are numerous ways to control the risks associated with working on roads or road-related areas. Examples of traffic control measures that may be considered include:

- road closures
- footpath closures
- detours
- protective barriers, and
- traffic controllers.

Where concrete pumping involves multiple truck deliveries, there should be a spotter, separate from any traffic controllers in place, who is responsible for controlling the delivery of the concrete trucks.

Further information can be found in the [Workplace traffic management guidance material](#).

Preparation for road travel

The manufacturer's instructions must always be followed. Where appropriate:

- secure outriggers (both hydraulic and manual), with a locking device specified by the manufacturer and stow in a travelling position to prevent lateral movement
- stow loose components (such as pipes, couplings and tools etc) in appropriate storage areas in accordance with manufacturer or other any relevant published guidelines
- disengage all drives to hydraulic pumps (for operating the concrete pump), boom and/or outriggers, and put the controls in the off position, and
- restrain booms in accordance with any manufacturers' instructions to ensure there is no unintended movement.

Noise

Operators of concrete placing equipment should be provided with suitable hearing protection and relevant training. The operator should remain aware of changes in noise levels during operation which may be an indicator of an unsafe condition.

Fumes

If possible, place the truck in a position that will eliminate or reduce the build-up of exhaust fumes.

If it is necessary to place the truck in an enclosed area, ensure that an adequate level of ventilation is maintained to prevent the build-up of hazardous exhaust fumes or that exhaust fumes are vented to open air.

You should ensure fumes are dispersed if the concentration level is likely to exceed safe levels, particularly when working in enclosed spaces.

Working near overhead powerlines

Electric lines can have significant risks including electrocution, arcing, explosion or fire causing burns, unpredictable cable whiplash and other objects being electrified like signs, poles, trees or branches. Contact with energised overhead or underground electric lines can be fatal regardless of the voltage they carry. It is not necessary to touch an overhead electric line to be electrocuted. A 'flashover' or 'arc' can electrocute people when close to a line conductor.

Ensure, so far as is reasonably practicable, no person or concrete pumping equipment at the workplace comes within an unsafe distance of an overhead or underground electric line.

If this is not reasonably practicable, carry out a risk assessment and implement control measures to manage the risks. The control measures must be consistent with requirements of the relevant electricity supply authority.

A safety observer should be used when the concrete pumping equipment is in motion and likely to enter a restricted work zone established around electric lines.

Most risks can be controlled by observing safe working distances for people and concrete pumping equipment working near electric lines. Safe working distances will depend on the type of work and the voltage of the electric lines. Contact the relevant electricity supply authority to determine the type of control measures required. This may include isolating the electric line for the duration of the work.

Contact with energised overhead electric lines may have an impact on parts of the concrete pumping equipment. If contact occurs, the concrete pumping equipment should be immediately placed out-of-service until it has been inspected by a competent person and proven to be safe to use.

Further information can be found in the [General guide for working in the vicinity of overhead and underground electric lines](#).

Electrical safety laws

Information about requirements for working near overhead powerlines can be provided by your local electrical safety regulator.

Contact details for your local electricity safety regulator can be found on the Safe Work Australia website.

Planning for work near overhead powerlines

Contact with overhead powerlines can pose a risk of electric shock or electrocution when operating a concrete placing boom. Do not operate concrete placing booms over the top of energised powerlines for the following reasons:

- the shape and height of the boom does not allow for a large separation distance from the powerlines
- boom movement may occur due to pumping motions, wind and 'bounce' as the boom is handled, and
- it can be extremely difficult for safety observers observing from the ground to judge distances and determine clearance from the powerlines.

Before setting up a concrete placing boom near overhead powerlines, you should conduct an inspection to identify the presence of overhead powerlines that may pose a risk.

The most effective way to eliminate any risk of electric shock is by turning off the power. You should discuss options for de-energising or re-routing the electricity supply with the relevant electrical network operator (electricity supplier).

Approach distances

Prior to starting work, you should determine what approach distances and work zones (see Figure 1) are required for the safe operation of the concrete pumping equipment and the safety of the operator and other workers.

The approach distance for each work zone will vary depending on the voltage of the overhead electric line and the level of authorisation of each person doing the work. As the risk increases, a greater approach distance is required.

There are three work zones (see Figure 1 below):

- **Zone C** is a No Go Zone closest to and surrounding the electric line where Electricity Supply Authority approval is required. A 'permit to work' may be required.
- **Zone B** surrounds the electric line and is further away than Zone C. It is for authorised people. Authorised people are workers who have successfully completed a recognised training course in overhead line electrical hazards so are permitted to work in Zone B.
- **Zone A** is furthest away from the electric line and is for unauthorised people. Unauthorised people are workers who have not received training in overhead line electrical hazards and do not have sufficient training or experience to enable them to avoid the dangers from overhead electric lines and associated electrical equipment.

Figure 1 Work zones in the vicinity of overhead electric lines

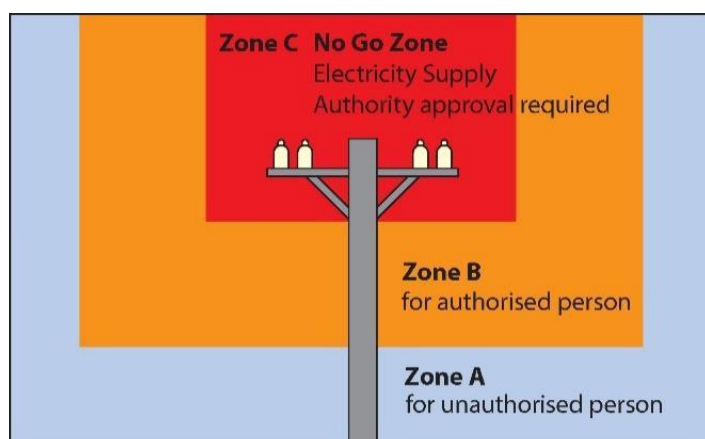

Refer to the relevant electrical safety authority for further advice. Australian standard AS2550.15:2019 *Cranes, hoists and winches – safe use – concrete placing equipment* provides additional guidance.

The safety observer zone

Concrete pumping equipment is in a safety observer zone when it is possible that a part of the plant or a person, equipment or tools could enter zone B operations.

A concrete pump is not operating in a safety observer zone when:

- high voltage electric lines have been de-energised, isolated or earthed
- limiting devices are used to warn the operator or prevent any part of the plant from entering Zone B—as long as the limiting device is effective under stress conditions and is regularly inspected by a competent person, or
- physical barriers stop any part of the plant entering Zone B.

Figure 2 Safety observer zone for overhead electric lines on poles and towers

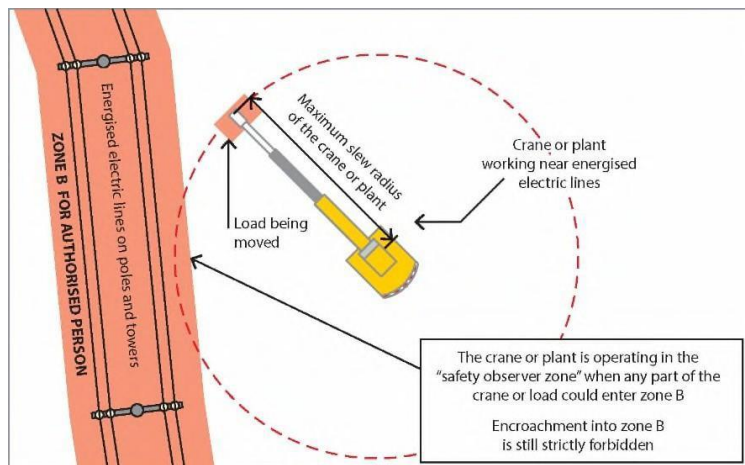

Safety observer

A safety observer should be used when the concrete boom is in motion and is likely to enter Zone B. The safety observer should:

- mark the border of Zone B with suitable markers e.g. red warning tape easily seen by the operator
- warn the operator if a part of the concrete pumping equipment is about to enter Zone B
- stop unauthorised people entering Zone B
- communicate effectively at all times with the operator and warn them about an approach to Zone B
- be provided with specialist communication equipment where there is a barrier to communication
- be trained to perform the role, and
- have the authority to stop the work at any time.

A safety observer is used to observe and advise the pump operator if the line or any part of the pump is likely to come within an exclusion zone of an overhead powerline.

Authorised people who work closer than Zone B and safety observers who observe the work should successfully complete a relevant training course provided by a registered training authority. They should be assessed as competent to carry out their work tasks in the vicinity of energised electric lines and exposed parts, and written certification should be verified.

Safety observers must be competent to implement control measures in an

emergency and to rescue and resuscitate a worker if necessary. Authorised people and safety observers must be re-assessed annually to ensure their ongoing competency to rescue and resuscitate and should also be re-assessed to ensure their competency to work in the vicinity of overhead electric lines.

The safety observer should encourage concrete pumps to be located away from the exclusion zone to prevent possible contact. When that is not possible, adopt other suitable precautions to prevent encroachment.

Controlling risks

Where it is reasonably practicable, the hazard must be eliminated, for example by removing energised electric lines from work areas. Consider:

- de-energising the electric line, or
- isolating and earthing the line for the duration of the work, or
- re-routing the electric line away from the work area.

Where elimination is not reasonably practicable, the risks must be minimised. Consider substituting the hazard or work practice with something safer, for example by using alternative plant that cannot enter an unsafe zone.

You must ensure, so far as is reasonably practicable, that any person, part of the concrete placing boom and/or the drop hose does not enter Zone B.

There are many ways this could be achieved, such as:

- setting up the concrete placing boom in a position that keeps it outside the restricted work zone
- erecting a physical barrier, made of non-conductive materials, to prevent any part of the concrete placing boom or person entering an unsafe distance. This may require isolating the electricity supply while the barrier is installed.

When implementing a system to maintain the exclusion zone, consider factors including:

- identifying the minimum clearance distance from the closest part of the concrete placing boom to the powerline
- allowing for sway or sag of the powerlines (sway is usually caused by wind, while sag may vary as the temperature of the line varies)
- ensuring that persons, plant and vehicles always stay outside the restricted work zone, and
- using a safety observer who observes the operation of the concrete placing boom.

The identified minimum clearance distance may need to be greater than the prescribed distance to ensure there is no breach of the restricted work zone.

There are devices available that assist in increasing protection from a hazard, including:

- warning signs to indicate the location of overhead powerlines
- tiger tails or line markers on overhead powerlines to act as a visual aid to highlight the location of the powerline.

Unloading and setting up of concrete pumping pipes also poses a risk of contact with overhead powerlines. Keep pipes parallel to the ground when setting up near overhead powerlines.

Contact with power lines

If contact with power lines is made:

- stay calm
- do not attempt to touch the concrete pumping equipment until a competent person says it is safe to do, in case the plant is 'live'
- if you must leave the concrete pumping equipment, for example in the event of an imminent hazard such as fire, jump clear to the ground with both feet together. Do not remain in contact with the concrete pumping equipment when you land on the ground. Shuffle or jump with both feet together away from the plant as the ground may be charged. Jump or shuffle until you are at least eight metres clear of the vehicle, powerlines or anything in contact with them
- keep the area clear of people, including workers and pedestrians
- notify the site manager/supervisor and call the relevant authorities immediately
- if possible, follow a competent person's advice and attempt to break contact with the powerline
- if a competent person says it is safe to do so, exit the machine. The machine should be checked for arcing and other damage. Inform the local power authority so they can check and repair the power lines, and
- keep a safe distance from the concrete pumping equipment and the powerlines until help arrives.

See the [Working in vicinity of underground and overhead electricals lines guidance material for further information.](#)

Inspection and maintenance

Concrete placing booms

You should ensure that concrete placing booms are regularly maintained in accordance with manufacturer's instructions to prevent structural or mechanical failure. Due to the pulsating nature of concrete pumping operation, equipment is prone to fatigue cracks and also rust from water ingress.

When inspecting concrete placing booms, consider:

- 7.1.1 all functions and their controls for speeds, smoothness of operation and limits of motion
- 7.1.2. all emergency and safety devices
- 7.1.3. lubrication of all moving parts, inspection of filter elements, hydraulic oil, and coolant, as specified by the manufacturer, and
- 7.1.4 visual inspection of structural components and other critical components such as fasteners, pins, shafts, welds and locking devices.

The erection and dismantling of concrete placing booms should be conducted in accordance with the manufacturer's instructions. Refer to Australian Standard AS2550.15:2019 *Cranes, hoists and winches – safe use – concrete placing equipment* for further guidance.

General

Appropriate planned inspections and preventative maintenance programs are essential for safe operation of concrete placing equipment. The inspections and maintenance should be carried out at intervals as specified by the manufacturer.

You should also ensure that all warning and safety signs/stickers are in good condition, legible and positioned on all equipment (after being inspected and found to be serviceable).

Pre-operational inspections

Before the start of each work period, all concrete pumping/placing equipment should be given a visual inspection and function test. You should follow the manufacturer's instructions and recommendations.

Routine inspections

You should establish an appropriate program of monthly inspections of all equipment to identify if preventative maintenance is required, in accordance with the manufacturer's recommendations. You should consider the equipment's working environment and its frequency of use. Keep details of these inspections in the appropriate log book, and a copy kept in the unit.

Periodic inspections

All concrete pumping equipment should be inspected by a competent person in accordance with the manufacturer's specifications, or at least annually.

Where not specified by the manufacturer, inspection intervals should be based on actual hours of use (as recorded by the operating-hours meter), increasing in frequency as the plant ages.

The periodic safety inspection includes a comprehensive inspection of the plant, its support structure, and outriggers (where fitted)

Inspection report

A comprehensive inspection report should be completed prior to the plant re-entering service. The report should include:

1. a summary of the history of the concrete pumping equipment prior to the periodic inspection being carried out, unless this is unavailable (if unavailable, the periodic inspection is likely to be more comprehensive)
2. where provided, a copy of the inspection criteria specified by the manufacturer
3. extracts of the manufacturer's maintenance manual detailing wear tolerances, bolt torques, and other relevant instructions followed during the inspection process
4. a list of work carried out on the boom
5. photographs of the unit during the inspection process including photos of damage, wear or cracking
6. a list of competent persons carrying out work on the unit as part of the inspection
7. signed statements from persons involved in the assembly process in relation to:
 - slew ring bolts being installed correctly (taking into consideration bolt type, lubricant if used, and bolting sequence)
 - pin and pin retainers installed correctly
 - hydraulics components installed correctly including a statement that replaced hydraulics components meet the manufacturer's specifications and that fittings have all been tightened to the correct torque
8. confirmation that hydraulic cylinders have been creep tested and are satisfactory, and
9. a summary of parts replaced with copies of receipts for parts provided in the report appendices.

Where some of the work has been contracted to external parties, provide a description of this work and copies of invoices in the appendices.

Where the competent person has made the decision not to dismantle the plant, or parts of the plant, they should document a comprehensive rationale for their decision.

Repair following an incident

In the event of an incident where structural failure has occurred or the plant has overturned, ensure the plant is assessed by the boom manufacturer or a competent person. Analyse the circumstances of the incident to determine the main contributing factors and possible reasons for the failure (i.e. soft ground, design abnormalities, normal wear, collision with other plant, etc).

Where the plant is to re-enter service, the manufacturer or competent person may oversee the following additional measures:

1. determine the components that may have been damaged that will need to be inspected
2. dismantle the plant, if needed, to enable the inspection of potentially damaged components
3. replace damaged components with new components that meet the

- design specifications of the manufacturer
4. function test the re-assembled boom, including through load testing, and
 5. prepare a detailed report on the repair of the boom that includes a statement that the concrete placing boom is safe to operate.

Log books and inspection record sheets

Records of tests, inspections, maintenance, commissioning, decommissions, dismantling, and alterations must be kept for registered concrete placing booms and made available for examination as required.

Records must be kept for the period the concrete pumping equipment is used, or until control is transferred to another person. The following should also be adhered to:

- keep instruction manuals (with sufficient instructions for operation, maintenance and repairs) with the pump unit and/or boom
- keep all manuals up-to-date with any additional information from the manufacturer
- keep maintenance and repair manuals in a safe place at the registered premises, including a parts catalogue
- keep maintenance log books up-to-date, on the pump, and available on request at the workplace, and
- ensure all log books and inspection record sheets show complete details of all inspections, tests, repairs, replacements and modifications carried out.

Keep evidence that the pump and associated equipment have been inspected and certified as 'suitable for continued service' (i.e. in a safe working condition) with the unit. They should be available to the principal contractor or person in control of the workplace for inspection (on request) before the unit is allowed to operate on site.

Appendix A – Concrete delivery

This table provides useful information on managing health and safety risks when receiving concrete delivery and delivering concrete to the pump hopper. This list is not exhaustive.

When receiving concrete delivery:	
	Do the concrete delivery trucks have clear and safe access to approach and leave the receiving hopper of the pump?
	If necessary, is a spotter or traffic controller being used to safely direct the movement of the trucks?
	Are all concrete delivery trucks fitted with flashing hazard lights and audible reversing lights that are activated when the truck is in reverse?
	Have you ensured no worker is standing between the reversing concrete delivery truck and the hopper?
	Have you ensured concrete delivery trucks do not reverse into the exclusion zone if they cannot see the spotter or traffic controller?
	Have you ensured the concrete chute on concrete trucks is only moved when the truck is stationary? <i>It is preferable that for the truck driver to perform this task. If another worker carries out the task, first obtain permission from the driver</i>
	Is the concrete receiving hopper at a height that allows a gravity flow of concrete into the hopper?
	Where low slump concrete is to be used and additional ramping is available for the concrete delivery truck, are the ramps specifically designed to ensure the truck cannot back off the ramps, ensure the truck remains stable and have a non-slip surface?
When delivering concrete to the pump hopper:	
	Is the receiving hopper positioned so it can receive a concrete flow readily?
	Have you provided a grate to prevent access to dangerous moving parts such as agitator mechanisms and valve gear?
	Are the hopper grates functioning and designed for opening fitted with an interlock system that de-activates both the paddles and the valve gear?
	Is the emergency stop button accessible to the concrete pump operator?
	Is the grate constructed of parallel bars which are spaced so that it is not possible for a person's hand to reach the danger area of the agitator and valve gear?

Appendix A.1 – Hopper Safety Warning

When delivering concrete to the pump hopper the following should be ensured:

- the receiving hopper of the concrete pump should be positioned so that it can receive a concrete flow readily from the discharge chute of a concrete delivery truck
- a grate is to be provided to prevent access to dangerous moving parts such as agitator mechanisms and valve gear (“S – tube” or “rock valve”). Hopper grates designed for opening are to be fitted with an interlock system that de-activates both the paddles and the valve gear. This system is to ensure that there is no energy in the system that can cause movement of the agitator mechanism or valve gear after the interlock switch is activated (i.e. from remaining hydraulic pressure in the accumulator)
- the emergency stop button should be accessible to the concrete pump operator
- the grate should be constructed of parallel bars which are spaced so that it is not possible for a person’s hand to become trapped (this spacing should not exceed 75mm)
- the distance from the top of the grate to any moving parts should be at least 100mm.

When cleaning out the pump or hopper the operator should ensure the manufacturer’s cleaning instructions are followed.

To prevent the risk of entanglement the following should be considered:

- mechanically locking moving parts in position
- shutting down the equipment
- disengaging the hydraulic pumps
- exhausting accumulated hydraulic or air pressure and allowing time for the pressure to be fully released from all systems
- ensuring the pump is not under pressure before it is dismantled
- not allowing any part of the worker’s body to be placed into the pump or hopper while cleaning.

NOTE: Where fitted, the interlocked cut-out switch on the hopper grille should not be relied on to prevent movement of parts during cleaning

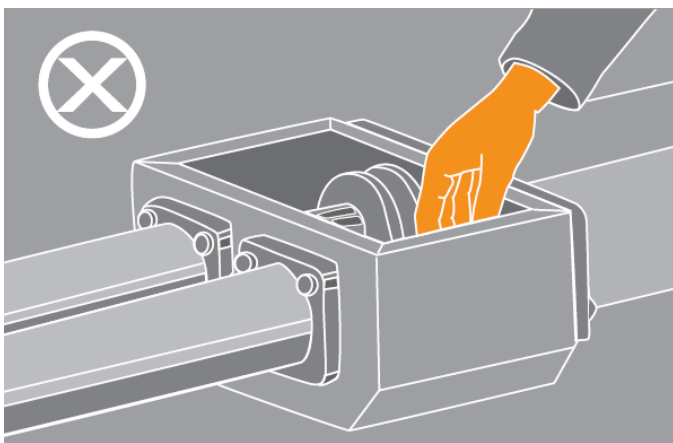

Appendix B – Concrete pumping

This table provides useful information on managing health and safety risks when pumping concrete. This list is not exhaustive.

	<p>Is only the line hand located directly under the boom?</p> <p><i>This is needed to effectively move the concrete placing boom's drop hose. Only the line hand can be directly under the concrete placing boom. However, the timespent under the raised boom can often be reduced by manoeuvring the hose from the side to avoid working directly under a raised boom.</i></p>
	<p>Have you checked the delivery hose for damage prior to it being fitted?</p>
	<p>Where the delivery hose is positioned over or above any working or public area, has it been fitted with a suitable stop at the outlet end?</p>
	<p>Have you avoided damage to the hose during use?</p>
	<p>Have you ensured the delivery hose fitting on the boom pump is secured in position by a safety chain, sling or other retaining device?</p>
	<p>Are you using a delivery hose that has a pressure rating to accommodate the pumping concrete pressure?</p>
	<p>Have you followed manufacturer's requirements on the maximum size and length of hose that may be suspended?</p>
	<p>Are reducers being used as per the manufacturer's recommendations to avoid overload of the delivery hose or other parts of the unit?</p>
	<p>Is the line hand wearing suitable eye protection (i.e. complying with AS/NZS 1336 Eye and face protection guidelines)?</p>

Appendix C – Minimising the risk of hose whip

This table provides useful information on managing health and safety risks of concrete pumping through minimising the likelihood of hose whip. This list is not exhaustive.

	<p>Have you ensured you only pump concrete that is a pumpable mix as specified by the concrete supplier?</p> <p><i>Other types of concrete can block the line and cause hose whip</i></p>
	<p>Have you ensured that concrete has not solidified in the line?</p>
	<p>Are you using appropriately trained operators?</p>
	<p>Have you started the pump up slowly?</p>
	<p>Have you ensured you are not using a rubber delivery hose with metal fittings attached to the free end?</p>
	<p>Have you set up an exclusion zone?</p>
	<p>Have you ensured you do not stretch the delivery hose to reach the pouring location?</p>
	<p>Are flexible hoses on line pumps secured in place when priming or clearing blockages?</p>
	<p>Are workers wearing the appropriate PPE, including safety helmets?</p>
	<p>Are you maintaining good housekeeping around the work area to reduce the likelihood of tripping?</p>
	<p>Have you ensured you do not let more hose hang from the boom than that allowed by the plant manufacturer?</p>
	<p>Have you ensured you do not allow concrete to drop out of the hose when pumping is stopped, as this can allow air to enter the system?</p>
	<p>Have you blown out or sucked in the mix in the lines before moving the boom?</p>
	<p>Have you sought verification from the concrete delivery truck owner of when the bowl was last descaled/debugged?</p>
	<p>Have you maintained an adequate level of concrete in the hopper to prevent air ingress?</p>
	<p>Have you kept watch of the consistency of the mix and advised the operator of any issues?</p>
	<p>Have you used the emergency stop if lumps or objects are identified?</p>

Appendix D – Blockages

This table provides useful information on managing health and safety risks through avoiding blockages when pumping concrete and safely clearing them when they occur. This list is not exhaustive.

To avoid blockages:	
	<p>Have you ensured the concrete mix is not too stiff or too wet?</p> <p><i>A mix that is too stiff can't be pumped because it will not fill the pumping cylinders and the pumping pressures will be excessive. A mix that is too wet can cause the mix components to segregate by allowing heavier materials to settle.</i></p>
	<p>Where recycled or remanufactured aggregate is used, have you checked whether an additive may be required to assist with binding the mix together?</p>
	<p>Is the system sized or designed properly for the pump capacity to ensure the pumping pressure is sufficient to move the concrete over the full length of the pipeline?</p>
	<p>Have you adequately primed and lubricated the pipeline prior to commencing the concrete pumping operation?</p>
	<p>Have you minimised the number of bends and short bends in the pipe or hose, as these will increase the concrete pumping pressure?</p> <p><i>If the reducer connecting the concrete pump to the pipeline system is too abrupt, the pumping pressure can increase and cause a blockage.</i></p>
	<p>Have you cleaned pipelines and hoses properly to avoid blockages caused by the setting of old concrete?</p>
	<p>Have you replaced damaged or defective couplings, gaskets, or weld collars?</p> <p><i>Excessive component wear in parts of the concrete pump can cause segregation of the concrete mix and lead to blockages.</i></p>
When clearing blockages:	
	<p>Have all people been excluded from the pipeline area, except for workers involved in clearing the line?</p>
	<p>After locating a blockage or rock jam, have you ensured the line is no longer under pressure before attempting to clear it?</p> <p><i>Reverse the pump to reduce the pressure</i></p>
	<p>Have you ensured you do not straddle a horizontal line when opening a coupling?</p> <p><i>You should stand to one side and lift the line so that free-flowing concrete runs out. Bend the hose or tap on the pipeline near the jam and shake out loose particles</i></p>
	<p>If pressurisation of the line is used to clear the blockage, have you taken particular care to exclude all people from the line vicinity and, in particular, the delivery hose, in case of hose whip?</p> <p><i>Restrain the hose from movement and attach a catchment device or properly designed receptacle to the discharge end of the pipeline to safely catch any projectiles, while still allowing concrete to flow. Workers should not try to restrain the hose by hand.</i></p>

Appendix E – Cleaning

This table provides useful information on managing health and safety risks when cleaning the concrete delivery line. This list is not exhaustive.

When cleaning the concrete delivery line:	
	Have you ensured only competent persons carry out line cleaning?
	Have you followed manufacturer's instructions?
	Have you used water in preference to air to minimise the risk of projectiles?
	Have you ensured there is always a connection to atmosphere (air relief valve) as well as the air entry point to the pipeline? <i>This allows the system to be depressurised before removing any pipeline. Do not attempt to take a line apart to clean out a blockage or to dismantle it until after the pressure has been relieved.</i>
	Have you ensured no pipeline connection or fitting is disconnected unless it is free of internal pressure?
	Have you ensured the pump operator remains at the pump controls while the pipeline is pressurised?
	Have you ensured you always remove the rubber delivery hose at the end of the pipeline, so that the hose cannot whip if the line is blown out?
	Are all parts of the pipeline secured to prevent movement during purging?
	Is a positive catchment device or properly designed receptacle attached to the discharge end of the pipeline to safely catch the cleaning device?
	Have you restrained concrete lines from moving (if using a properly designed receptacle, such as a concrete truck bowl)? <i>Restraint by attachment to the concrete truck's ladder is not an adequate control.</i>
	Have you ensured all workers are kept away from the discharge end while the concrete is under pressure?
	Are all workers involved wearing adequate PPE?
When cleaning the concrete pump:	
	Have you fitted and maintained a physical barrier at all times during operation to prevent a person contacting moving parts in a hopper?
	Where cleaning or dislodgement of material requires a worker to enter the hopper, have you shut down the equipment and exhaust any accumulated hydraulic or air pressures that may allow the elements to move or rotate, even with the engine stopped?
	Have you ensured that cleaning is not undertaken alone?



Australia's exclusive distributor
of JUNJIN concrete pumps

JUNJIN

ABN: 47 615 107 054

Australia's leading supplier of Australian made and imported concrete pumps

2. PIPELINE

2.2. PUMP LOCATION AND PIPELINE LAYOUT

By careful planning the position of the concrete pump and pipeline, a smoother job performance and pumping record will be attained. At all times the grate on the hopper should be closed for safety. The pump should be placed as close as possible to the discharge point. Where fast turnaround is required, it should be positioned such that two (2) ready mix trucks can have access to the pump hopper. It should be noted that the actual pressure in the pumping line on the concrete is less than the hydraulic pressure as shown on the pump main pressure gauge. It is advisable to learn the ratio of your particular pump (see specification sheet). 4.6:1

2.3. PIPELINE SET-UP

When setting up the pipeline all care should be taken that the pipeline is well supported and fixed to minimise line movement which excessively stresses the clamps and joints. As few as possible bends should be used to keep pumping pressure to a minimum. Firstly, a check of all the pipeline equipment should be made to see that it can withstand all the pumping pressure the pump can produce if the concrete line becomes blocked.

Monthly checks of the wall thickness of the pipeline should be carried out with a thickness tester and any pipes too thin for use should be discarded. For general pumping, a thickness of 1.5mm is minimum for safety. All clamps should be inspected for cracks; all welded joint shoulders should be checked for weakness or signs of fatigue. Ensure that the pipe strength and wall thickness of your pipes match the performance of your pump and the requirements of the project you work on.

HEAD OFFICE - NSW

15 – 17 Beaumont Rd
Mt Kuring-gai NSW, 2080
P: 61 2 9457 8044
F: 61 2 9457 9205

QUEENSLAND

Unit 1/35 Sodium St
Narangba, QLD, 4504
P: 61 7 3888 8988
F: 61 7 3888 8999

VICTORIA

2/28 Titan Drive
Carrum Downs, VIC, 3201
P: 61 3 8787 5844
F: 61 3 8787 5855

WESTERN AUSTRALIA

10 Industry Street
Malaga, WA, 6090
P: 61 8 9248 4811
F: 61 8 9248 3511

email sales@flowcrete.com.au



Australia's exclusive distributor
of JUNJIN concrete pumps

JUNJIN

ABN: 47 615 107 054

Australia's leading supplier of Australian made and imported concrete pumps

3. PUMPING CONCRETE

Use this checklist as a guide to reducing possibilities of a breakdown.

3.1. INITIAL PUMP PREPARATION

Checklist;

1. Check oil and water level in engine where necessary.
2. Check fuel level is sufficient for job.
3. Check hydraulic oil level in main tank.
4. Check lubricant in water box is clean. Provided concrete piston seals are not leaking, a mixture of 50:50 hydraulic oil and water should be used to top water box up. To cycle the pump without any lubricant can cause permanent damage to the pumping seals.
5. Grease all nipples on rear end until clean grease emits from all positions.
6. Check hopper is empty of foreign bodies.
7. In cold weather do not start engine unless hydraulic oil temperature is above minus 10 degrees Celsius. If the oil is too cold it will cause the oil pump to cavitate which causes permanent pump damage. The engine should always be run at 1200 rpm until oil warms up.
8. Check 'S' piece is internally clean.

3.2. PUMP START UP PROCEDURE

1. Position pump switch to 'STOP' and agitator control valve handle (if fitted) to center position. Ensure no foreign material is in the hopper.
2. Ensure park brake is engaged.
3. Start truck engine, depress clutch pedal and select 1:1 ratio gear. This is normally 5th gear on a 6 speed gearbox.
4. Switch PTO on and release clutch slowly. You will hear the hydraulic pumps start and the engine revs will increase slightly.
5. The control panel is now energized and all controls will be operational.
6. Allow hydraulic oil temperature to warm up before commencing pumping.
7. Switch pump/off/remote switch to 'pump' and the forward stop/reverse switch to 'forward'.
8. Check that the machine cycles automatically and there are no oil leaks.
9. If all checks are OK, the machine is now ready for slurring up the line. Turn the pump off.

HEAD OFFICE - NSW

15 – 17 Beaumont Rd
Mt Kuring-gai NSW, 2080
P: 61 2 9457 8044
F: 61 2 9457 9205

QUEENSLAND

Unit 1/35 Sodium St
Narangba, QLD, 4504
P: 61 7 3888 8988
F: 61 7 3888 8999

VICTORIA

2/28 Titan Drive
Carrum Downs, VIC, 3201
P: 61 3 8787 5844
F: 61 3 8787 5855

WESTERN AUSTRALIA

10 Industry Street
Malaga, WA, 6090
P: 61 8 9248 4811
F: 61 8 9248 3511

email sales@flowcrete.com.au



Australia's exclusive distributor
of JUNJIN concrete pumps

JUNJIN

ABN: 47 615 107 054

Australia's leading supplier of Australian made and imported concrete pumps

3.3. CONTROL PANEL OPERATION

3.3.1 AUTOMATIC PUMPING

1. Turn 'FORWARD/REVERSE' switch to 'FORWARD'. Turn 'PUMP/STOP/TEST' switch to pump. This will allow hydraulic/concrete pressure to be developed.

The concrete pump will draw concrete in through the hopper and discharge concrete through the 'S' tube to the outlet.

2. Turn 'FORWARD/REVERSE' switch to 'REVERSE'. Turn 'PUMP/STOP/TEST' switch to 'PUMP'. The concrete pump will draw concrete in through the pipeline and discharge concrete into the hopper.

3.3.2 REMOTE PUMPING

Turn 'FORWARD/REVERSE' switch to 'FORWARD'. Turn 'PUMP/STOP/REMOTE' switch to 'REMOTE'. The concrete pump will draw concrete in through the hopper and discharge concrete through the 'S' tube to the outlet. Automatic sequencing will be controlled by the signal of the remote control.

3.3.4 TESTING

Switch 'TEST/FORWARD/REVERSE' TO 'TEST'. Switch 'STOP/PUMP/REMOTE' to pump. This will drive the cylinders to one end and stall, thus building up hydraulic pressure.

3.3.5 WATER PUMP

Turn "water" to "On" when using water pump and "off" when not using water pump

NOTE: Continuous usage of the water pump for long periods of time will burn out fuse and will cause pump failure

3.4. SLURRYING UP

This should be done after agitator arrives.

For all types of concrete pumping through a delivery line, the line must be lubricated with slurry first. This lubrication wets the inside of the pipeline to stop the moisture being drawn from the concrete mix, thus causing a blockage. Flowprime should be used to the directions of the packet. For pipelines under 50 metres normally 40 litres of Flowprime should be mixed and poured directly into the pipeline.

An alternative method is to place a small amount of concrete from the agi truck into the bottom of the hopper then pour the slurry first and pump it down the line to lubricate the line. When all the grout is in the line the concrete should be poured into the hopper, the pump switched to 'PUMP' and the machine cycled slowly approximately 8-12 strokes until concrete flows freely from the delivery line.

HEAD OFFICE - NSW

15 – 17 Beaumont Rd
Mt Kuring-gai NSW, 2080
P: 61 2 9457 8044
F: 61 2 9457 9205

QUEENSLAND

Unit 1/35 Sodium St
Narangba, QLD, 4504
P: 61 7 3888 8988
F: 61 7 3888 8999

VICTORIA

2/28 Titan Drive
Carrum Downs, VIC, 3201
P: 61 3 8787 5844
F: 61 3 8787 5855

WESTERN AUSTRALIA

10 Industry Street
Malaga, WA, 6090
P: 61 8 9248 4811
F: 61 8 9248 3511

email sales@flowcrete.com.au



Australia's exclusive distributor
of JUNJIN concrete pumps

JUNJIN

ABN: 47 615 107 054

Australia's leading supplier of Australian made and imported concrete pumps

3.5 BLOCKAGE

If a blockage occurs during this operation or at any time during pumping the following steps should be followed:

1. Stop the pumping cycle by turning pump switch to 'STOP'.
2. Switch FORWARD/STOP/REVERSE switch to 'REVERSE'.
3. Turn pump switch to 'PUMP'. Cycle concrete pump for 2 to 3 strokes.
4. Switch FORWARD/STOP/REVERSE switch to 'FORWARD'. Pump forward slowly.
5. If machine blocks again, repeat steps 1 to 4. Looking for blockage position.
6. If blockage position cannot be identified, pump should be turned on and observe movement of the pipeline. Where the line stops *kicking* is the position of the blockage and it must be removed by hand.
Obvious position for blockages to occur are reductions and then bends in the pipeline.
7. After blockage position is located, it has to be cleared manually.
8. Carefully remove pipe clamps at blocked location.

Warning: Before attempting to disconnect pipeline ensure there is no residual line pressures.

9. Remove packed concrete from pipe or bend.
10. With blocked line disconnected, pump a small quantity of concrete on to the ground to ensure any other blockages are removed. Reconnect pipeline assembly.
11. Concrete pumping may be continued.

HEAD OFFICE - NSW

15 – 17 Beaumont Rd
Mt Kuring-gai NSW, 2080
P: 61 2 9457 8044
F: 61 2 9457 9205

QUEENSLAND

Unit 1/35 Sodium St
Narangba, QLD, 4504
P: 61 7 3888 8988
F: 61 7 3888 8999

VICTORIA

2/28 Titan Drive
Carrum Downs, VIC, 3201
P: 61 3 8787 5844
F: 61 3 8787 5855

WESTERN AUSTRALIA

10 Industry Street
Malaga, WA, 6090
P: 61 8 9248 4811
F: 61 8 9248 3511

email sales@flowcrete.com.au

PUMPABLE CONCRETE

Pumpable concrete must be capable of receiving the pressure applied to it without segregating. It must also be flowable and cohesive and must contain sufficient water and fines to lubricate the pipes. The mix must be made up of well graded materials and be without voids.

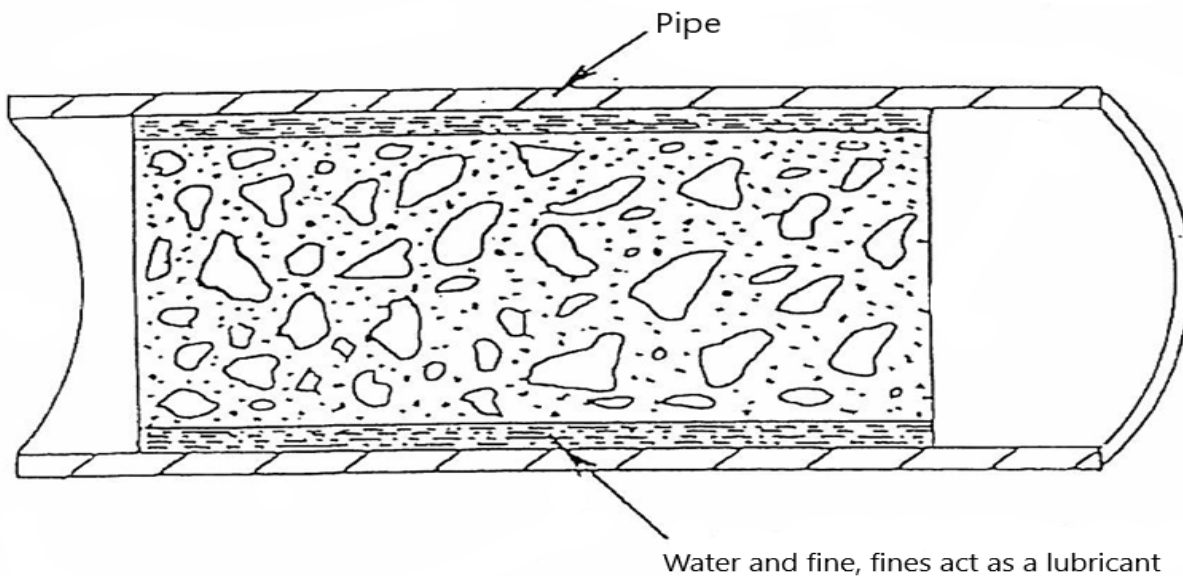

The specification will normally lay down the strength required and indicate the cement content per cubic metre, the water cement ration and the slump.

Within these criteria, it is then possible to modify the mix if necessary, to make it pumpable.

Assuming that sieve analyses are available for the sand and aggregates, the gradings should be examined first. If possible, plot the gradings on a combined grading curve and then eliminate gaps of partial gaps in the grading. These are the basic cause of all blockages.

HEAD OFFICE - NSW

15 – 17 Beaumont Rd
Mt Kuring-gai NSW, 2080
P: 61 2 9457 8044
F: 61 2 9457 9205

QUEENSLAND

Unit 1/35 Sodium St
Narangba, QLD, 4504
P: 61 7 3888 8988
F: 61 7 3888 8999

VICTORIA

2/28 Titan Drive
Carrum Downs, VIC, 3201
P: 61 3 8787 5844
F: 61 3 8787 5855

WESTERN AUSTRALIA

10 Industry Street
Malaga, WA, 6090
P: 61 8 9248 4811
F: 61 8 9248 3511

COMBINED AGGREGATE GRADING CURVES

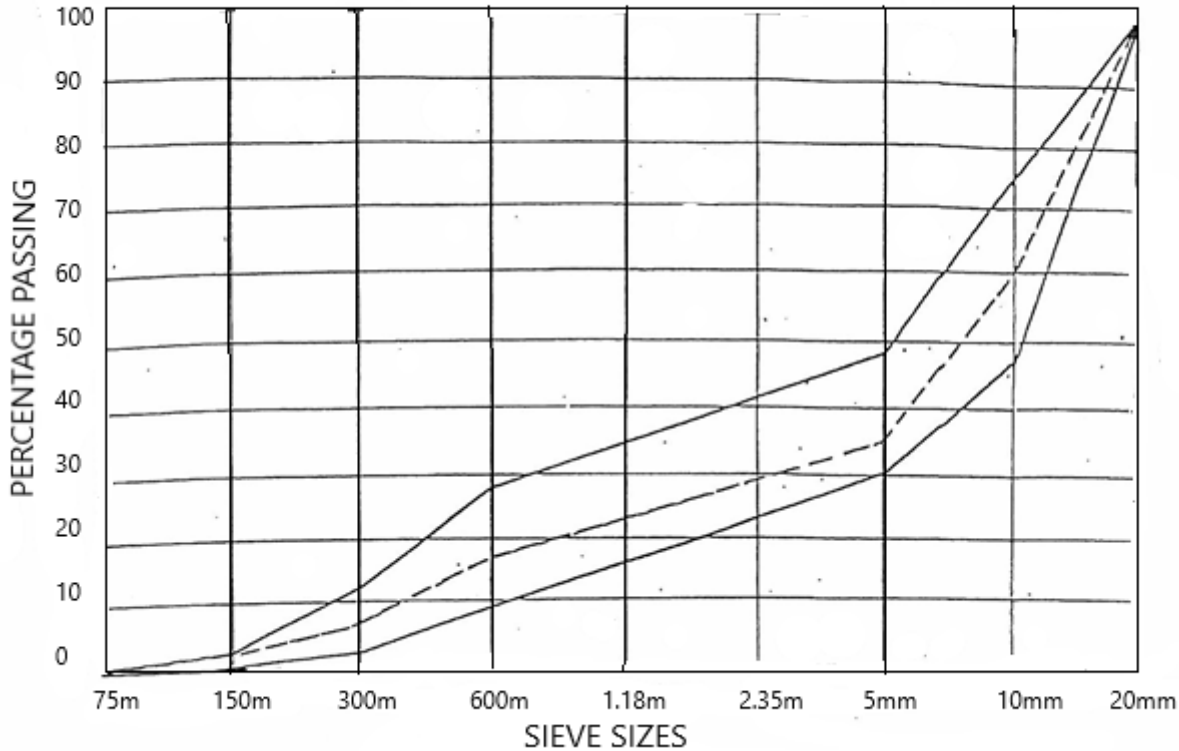

A good pumpable mix must follow the general shape of the grading curves or envelope.

The mix plotted here will pump well.

If the curve when plotted shows gaps then it must be adjusted.

If the curve fails to follow the general shape of the envelope it must be adjusted.

This approach is internationally accepted as a means of designing pumpable concrete.

The golden rule with pumpable concrete is to examine the fines. More than anything else it is the fines that regulate the pumpability. The better the sand in this respect the less is required.

Rounded aggregates pump better than angular or irregular aggregates.

If you have a wet concrete or high slump then you need more sand.

HEAD OFFICE - NSW

15 – 17 Beaumont Rd
Mt Kuring-gai NSW, 2080
P: 61 2 9457 8044
F: 61 2 9457 9205

QUEENSLAND

Unit 1/35 Sodium St
Narangba, QLD, 4504
P: 61 7 3888 8988
F: 61 7 3888 8999

VICTORIA

2/28 Titan Drive
Carrum Downs, VIC, 3201
P: 61 3 8787 5844
F: 61 3 8787 5855

WESTERN AUSTRALIA

10 Industry Street
Malaga, WA, 6090
P: 61 8 9248 4811
F: 61 8 9248 3511



Australia's exclusive distributor
of JUNJIN concrete pumps



ABN: 47 615 107 054

Australia's leading supplier of Australian made and imported concrete pumps

GUIDE OR SIMPLE QUICK REFERENCE

TO USE IT

Firstly, establish the sand zoning then the cement content.

As an example; if you have 350 kilos of cement and zone 3 sand then it can be seen that the sand content should be 34%.

If the slump is 150mm then add 3% sand.

If the aggregates are rounded then you can deduct 2% sand.

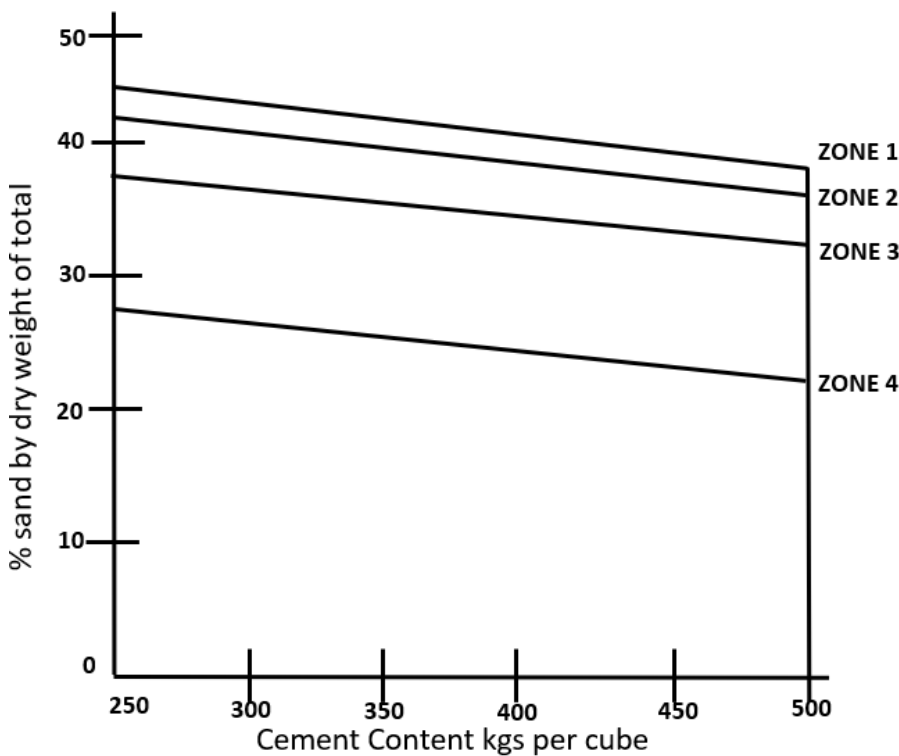

VARIABLE FACTORS	%
<u>Agg shape</u>	
Round	-2
Round/Irregular	-1
Irregular	0.0
Irregular/Angular	+2
Angular	+4
<u>Agg Size</u>	
20mm	+2
10mm	+4
<u>Slump</u>	
175mm	+4
150mm	+3
125mm	+2
100mm	+1

HEAD OFFICE - NSW

15 – 17 Beaumont Rd
Mt Kuring-gai NSW, 2080
P: 61 2 9457 8044
F: 61 2 9457 9205

QUEENSLAND

Unit 1/35 Sodium St
Narangba, QLD, 4504
P: 61 7 3888 8988
F: 61 7 3888 8999

VICTORIA

2/28 Titan Drive
Carrum Downs, VIC, 3201
P: 61 3 8787 5844
F: 61 3 8787 5855

WESTERN AUSTRALIA

10 Industry Street
Malaga, WA, 6090
P: 61 8 9248 4811
F: 61 8 9248 3511

email sales@flowcrete.com.au



Australia's exclusive distributor
of JUNJIN concrete pumps



ABN: 47 615 107 054

Australia's leading supplier of Australian made and imported concrete pumps

The next step I to make a trial mix based on the decision as to the proportions of aggregate, water cement ration etc. that you have so far made.

Look at the concrete in the mixer and see whether it looks creamy and rich. As the concrete is turned over by the blades of the mixer you should see the cement and sand, the concrete should hold together and it should not rattle in the mixer.

A well accepted test is to use a slump cone upside down, fill this carefully with concrete until it is well over the top of the wide part of the slump cone. Do not tamp it down. Then carefully lift the cone which is now full of concrete and if it is a pumpable mix the concrete should flow slowly out of the bottom of the slump cone. If it does not then the mix will require adjustment. We have found that this test is used by major cement mixer companies and is becoming increasingly accepted.

Naturally a slump test must be done using the correct procedures for this. We would suggest you start with a slump of at least 100mm if possible.

A few other useful tips for the inexperienced concrete pumper are:

1. Take some concrete in your hand and squeeze it and see whether it segregates. If water comes out through your fingers then it is unlikely to pump. If a nice rich creamy liquid of cement and sand squeezes through your fingers, that is a good sign.
2. Take a shovel full of concrete and throw it away, if the concrete leaves the shovel face easily, it is a favourable sign.
3. Experience will tell you the difference between a lean bony unpumpable mix and a nice rich creamy mix, but the above tests should all help the inexperienced pumper.

If you are on a building site away from a cement mixer yard probably using bag cement, and without technical laboratories, grading curves etc then you must use the aggregates that you have and make a pumpable concrete out of it.

We suggest that you start with the bag of cement. It is difficult to split the bags and therefore design the mix around one bag of cement at a time.

Then look at the sand. If the sand contains a lot of fines and looks well graded, to one bag of cement add two (2) parts by volume of sand and 2.5 of aggregate. Mix this to a 100mm slump and then carry out the tests. It is unlikely that this mix will fail to pump. If your sand is very sharp and coarse and lacking in fines then you need to reduce the amount of sand and aggregate relative to the cement as a first step we would suggest trying a 1:2 mix.

HEAD OFFICE - NSW

15 – 17 Beaumont Rd
Mt Kuring-gai NSW, 2080
P: 61 2 9457 8044
F: 61 2 9457 9205

QUEENSLAND

Unit 1/35 Sodium St
Narangba, QLD, 4504
P: 61 7 3888 8988
F: 61 7 3888 8999

VICTORIA

2/28 Titan Drive
Carrum Downs, VIC, 3201
P: 61 3 8787 5844
F: 61 3 8787 5855

WESTERN AUSTRALIA

10 Industry Street
Malaga, WA, 6090
P: 61 8 9248 4811
F: 61 8 9248 3511

email sales@flowcrete.com.au

ADMIXTURES

Admixtures used properly can turn an unpumpable concrete into a pumpable concrete. This diagram shows that there is a broad band of pumpable concrete and at the extremes you get unpumpable due to high resistance or unpumpable due to segregation. The additive or admixture aims to broaden this band of pumpable concrete.

A plasticiser or an air entraining agent normally helps to make concrete pumpable. In Norway where all concrete is air entrained due to the extremes of temperature, the addition of 5% air entraining is standard practice and this makes for a very good pumpable mix.

We would strongly recommend that you always take expert advice on admixtures and follow the manufacturer's recommendations.

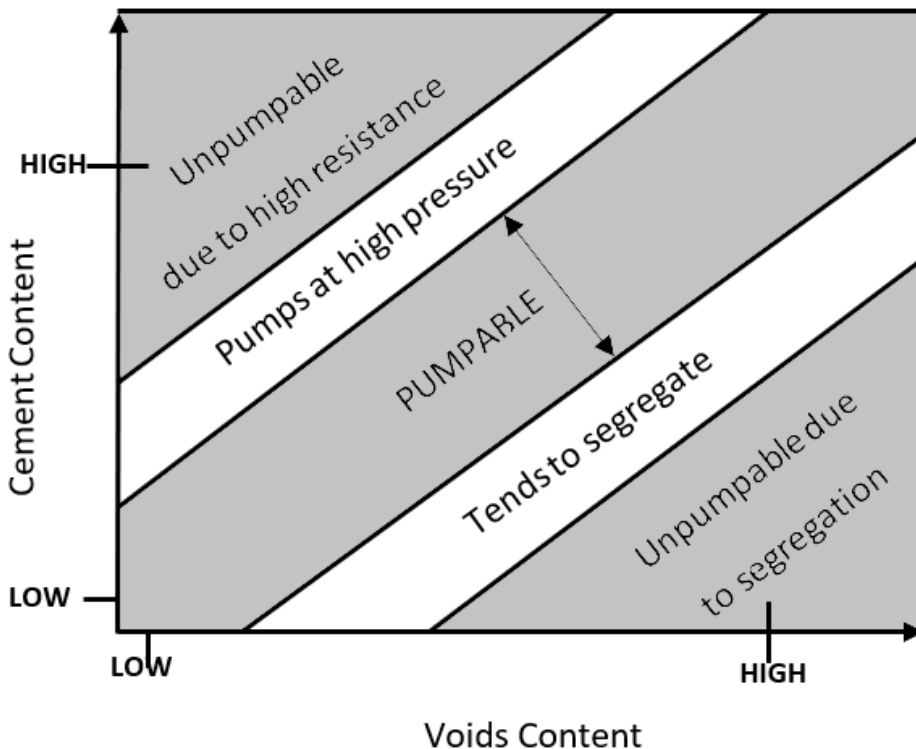

Diagrammatic illustration of the behaviour of given materials when pumped.

HEAD OFFICE - NSW

15 – 17 Beaumont Rd
Mt Kuring-gai NSW, 2080
P: 61 2 9457 8044
F: 61 2 9457 9205

QUEENSLAND

Unit 1/35 Sodium St
Narangba, QLD, 4504
P: 61 7 3888 8988
F: 61 7 3888 8999

VICTORIA

2/28 Titan Drive
Carrum Downs, VIC, 3201
P: 61 3 8787 5844
F: 61 3 8787 5855

WESTERN AUSTRALIA

10 Industry Street
Malaga, WA, 6090
P: 61 8 9248 4811
F: 61 8 9248 3511



Australia's exclusive distributor
of JUNJIN concrete pumps

JUNJIN

ABN: 47 615 107 054

Australia's leading supplier of Australian made and imported concrete pumps

4. MAINTENANCE

4.1 MAINTENANCE

After every pumping job the concrete pump should be thoroughly washed and kept in a clean and tidy condition.

The 'S' piece should be carefully checked and cleaned of any build-up of concrete inside. Failure to do so can cause clogging by progressive concrete build-up.

Check for build-up on end of piston heads and remove if evident. Inspection of the piston heads can be done by cycling the pump in reverse and looking at piston heads from inside the hopper.

1. Check gap between wear plate and wear ring. If adjustment nut cannot close gap to a maximum of 2mm, then the wear plate and wear ring should be replaced.
2. Check bolts connecting 'S' piece to spline shaft, ensuring they are tight.
3. Outlet seal on 'S' piece, remove outlet and grease inside diameter of seal.
4. Check concrete piston seals for excessive wear on seal lip. If lip is more than 30% damaged the seals should be changed.
5. Check coupling bolts of concrete piston. If loose, tighten.
6. Check external covering on all hoses for chaffing.
7. Check tightness of all fasteners.
8. Refer to engine manual for hour servicing and engine check list.

HEAD OFFICE - NSW

15 – 17 Beaumont Rd
Mt Kuring-gai NSW, 2080
P: 61 2 9457 8044
F: 61 2 9457 9205

QUEENSLAND

Unit 1/35 Sodium St
Narangba, QLD, 4504
P: 61 7 3888 8988
F: 61 7 3888 8999

VICTORIA

2/28 Titan Drive
Carrum Downs, VIC, 3201
P: 61 3 8787 5844
F: 61 3 8787 5855

WESTERN AUSTRALIA

10 Industry Street
Malaga, WA, 6090
P: 61 8 9248 4811
F: 61 8 9248 3511

email sales@flowcrete.com.au



Australia's exclusive distributor
of JUNJIN concrete pumps

JUNJIN

ABN: 47 615 107 054

Australia's leading supplier of Australian made and imported concrete pumps

4.2 POST COMMISSIONING / FOLLOW-UP MAINTENANCE

1. After fifty (50) hours, check and change all the hydraulic filters.
2. Check wear plate for even wear and minimum gap.
3. Check bolts on the 'S' piece.
4. Check coupling bolts.
5. Check gland housing bolts.
6. Check all tie rods.
7. Check bolts on the 'S' piece outlet.
8. Lubricate/Grease all nipples thoroughly
9. Check all hose ends for tightness.
10. Remove electrical control panel (front cover) and visually check wiring and switches.
11. Check main hydraulic gauge – reading is set to specification sheet.
12. Check swinger ram pressure gauge – set to specification sheet.
13. Check accumulator gas pressure – set to specification sheet.
14. Check the diesel/electric engine as per manufacturer's instructions.
15. Check the engine's mounting bolts.
16. Check water and oil levels
17. Check battery level and cleanliness.
18. Check all welded joints especially around the swinger ram mounts.
19. Check all the remaining fasteners.

The above procedures should be carried out monthly except for changing the hydraulic filter which should be changed every 500 hours.

HEAD OFFICE - NSW

15 – 17 Beaumont Rd
Mt Kuring-gai NSW, 2080
P: 61 2 9457 8044
F: 61 2 9457 9205

QUEENSLAND

Unit 1/35 Sodium St
Narangba, QLD, 4504
P: 61 7 3888 8988
F: 61 7 3888 8999

VICTORIA

2/28 Titan Drive
Carrum Downs, VIC, 3201
P: 61 3 8787 5844
F: 61 3 8787 5855

WESTERN AUSTRALIA

10 Industry Street
Malaga, WA, 6090
P: 61 8 9248 4811
F: 61 8 9248 3511

email sales@flowcrete.com.au



Australia's exclusive distributor
of JUNJIN concrete pumps

JUNJIN

ABN: 47 615 107 054

Australia's leading supplier of Australian made and imported concrete pumps

4.3 DAILY/WEEKLY/MOHTLY MAINTENANCE

DAILY MAINTENANCE:

1. Check gap between wear ring and wear plate 0.5 – 0.75 mm.
2. Grease all pins and hopper seal
3. Check lubrication oil is in water box.
4. Visually check connections on top of heads.
5. Visually check all electric wiring.

WEEKLY MAINTENANCE:

1. Check that there is no excessive wear in pins and wear plate when pump is cycling.
2. Check bolts in couplings 'S' piece.
3. Check in water box for slurry, if excessive slurry appears, concrete piston seals needs replacing.
4. Check oil level in hydraulic tank.
5. Check 'S' piece internally for any build-up of concrete.
6. Check all hydraulic hoses for signs of external scuffing.
7. Check main hydraulic pressure by placing auto manual switch into manual and switch pump switch to pump. The maximum relief valve pressure will show on main pressure gauge. Pressure should read 200 BAR.

MONTHLY MAINTENANCE:

1. Follow procedures in Section 4.2.
2. Hydraulic filters should be changed at every 500 hours.
3. Inspect hydraulic oil tank breather and clean or replace where necessary.

HEAD OFFICE - NSW

15 – 17 Beaumont Rd
Mt Kuring-gai NSW, 2080
P: 61 2 9457 8044
F: 61 2 9457 9205

QUEENSLAND

Unit 1/35 Sodium St
Narangba, QLD, 4504
P: 61 7 3888 8988
F: 61 7 3888 8999

VICTORIA

2/28 Titan Drive
Carrum Downs, VIC, 3201
P: 61 3 8787 5844
F: 61 3 8787 5855

WESTERN AUSTRALIA

10 Industry Street
Malaga, WA, 6090
P: 61 8 9248 4811
F: 61 8 9248 3511

email sales@flowcrete.com.au



Australia's exclusive distributor
of JUNJIN concrete pumps

JUNJIN

ABN: 47 615 107 054

Australia's leading supplier of Australian made and imported concrete pumps

4.4 HYDRAULIC OIL

N.B: After the initial 50 hours, change all hydraulic filters.

Grade of hydraulic oil: ISO 68

If hydraulic oil turns a milky colour it has been contaminated with water. Immediately drain from machine and completely replace.

If hydraulic oil turns to a dark colour and smells pungent, the oil has excessively overheated. Replace oil immediately.

4.5 TROUBLE SHOOTING

PUMP CYCLED BUT DOES NOT GIVE FULL LENGTH OF STROKE:

This is called 'short stroking'. To correct problem, switch machine to test until pump gives full stroke. If pump is over made up it will automatically adjust the amount of oil in the closed loop and start cycling.

PUMP JAMS IN MID STROKE:

This problem can only occur when there is a concrete blockage. At no time should the concrete be forced further as this could create more problems. First, turn pump/stop switch to stop. Select reverse and re-select pump. Let the pump cycle 3 times and then select forward. If a further blockage occurs the line will have to be checked and blockage cleared. Note; blockages normally occur in bends and or reducers or rubber hoses.

PUMP WILL NOT STOP OR START PUMPING:

Place finger on rubber boot on dump solenoid which is located on relief valve. When pump/stop switch is moved, you should detect movement back and forwards. If no movement occurs the wiring and connection plug should be checked for faults. If wiring is OK the top section should be removed, cleaned and replaced. A thorough inspection of all small parts is needed in cartridge.

HEAD OFFICE - NSW

15 – 17 Beaumont Rd
Mt Kuring-gai NSW, 2080
P: 61 2 9457 8044
F: 61 2 9457 9205

QUEENSLAND

Unit 1/35 Sodium St
Narangba, QLD, 4504
P: 61 7 3888 8988
F: 61 7 3888 8999

VICTORIA

2/28 Titan Drive
Carrum Downs, VIC, 3201
P: 61 3 8787 5844
F: 61 3 8787 5855

WESTERN AUSTRALIA

10 Industry Street
Malaga, WA, 6090
P: 61 8 9248 4811
F: 61 8 9248 3511

email sales@flowcrete.com.au



Australia's exclusive distributor
of JUNJIN concrete pumps

JUNJIN

ABN: 47 615 107 054

Australia's leading supplier of Australian made and imported concrete pumps

4.6 PRESSURE ADJUSTMENTS

Maximum pressure on the Swing Tube accumulator circuit should be 100 bar (1500 PSI)

Maximum pressure settings on the Main Pump should be 205 bar (3000 PSI)

The pressure in the Main Ram circuit will be visible on the Main Ram pressure gauge whenever pump is in test mode.

Adjust pressure on the maximum pressure settings as follows:

1. Engine speed set about 1500RPM
2. Wind compensator fully in on piston pump
3. Put in test mode (pump + manual)
4. The main ram will lock at the end of the stroke and the main pump will pressure out to maximum pressure.
5. Set manifold / block relief valve to 3200 PSI
1. Set main pump pressure to 3000 PSI. To increase pressure, loosen lock nut on relief valve and turn knob clockwise to preferred pressure. To decrease pressure turn knob anti-clockwise.
6. Wind compensator back out 2 ½ turns.

Maximum pressure settings on the Swing Ram circuit should be 100 bar (1500 PSI).

The pressure in the Swing Ram circuit will be visible on the Swing Ram pressure gauge whenever pump is in operation.

Adjust pressure on the Swing Ram circuit as follows:

1. To increase pressure, loosen lock nut on relief valve and turn knob clockwise to preferred pressure. To decrease pressure, turn knob anti-clockwise.

HEAD OFFICE - NSW

15 – 17 Beaumont Rd
Mt Kuring-gai NSW, 2080
P: 61 2 9457 8044
F: 61 2 9457 9205

QUEENSLAND

Unit 1/35 Sodium St
Narangba, QLD, 4504
P: 61 7 3888 8988
F: 61 7 3888 8999

VICTORIA

2/28 Titan Drive
Carrum Downs, VIC, 3201
P: 61 3 8787 5844
F: 61 3 8787 5855

WESTERN AUSTRALIA

10 Industry Street
Malaga, WA, 6090
P: 61 8 9248 4811
F: 61 8 9248 3511

email sales@flowcrete.com.au



Australia's exclusive distributor
of JUNJIN concrete pumps



ABN: 47 615 107 054

Australia's leading supplier of Australian made and imported concrete pumps

4.7 RECOMMENDED SPARE PARTS

<u>Description</u>	<u>Part No:</u>	<u>Quantity:</u>
Wear Plate	FM00439T	1
Wear Ring	FM00115T	1
Anti-Chip ring	FM00113	2
Wear Ring Locator	FM00448	1
S Piece 6"- 6" (Complete)	FM01158	1
Minor Link	FM00454	1
Spline Shaft	FM00436	1
Nut (Nyloc) UNF 1 ½	FP00070	1
Chromed Outlet	FM00502	1
Outlet Seal	FP00082	1
Hopper Outlet	FM00033	1
Linatex Hopper Seal 6"	FP00354	1
Piston Cups	FP00040	2
O Ring – Piston Cups	FP02393/1	2
Gland Packing	FP00045	2
Wiper Seal	FP00031	2
Bearing	FP00357	2
Pin Long 1" x 83mm	FM01108	1
Pin Short 1" x 71.5mm	FM00465	1
Bush 1. 3/8" OD 1" ID x 1"	FP00180	2
Bush 1. 3/8" OD 1" ID x 3/4	FP00356	2
Bush 1. 3/8" OD 1" ID x 5/8	FP00376	2
Bush Bronze 2" x 2.5" x 1.5"	FP00175	2
Element Return Filter	FP00528	1
Proximity Sensor	FP01363	1
Swing Over Ram Cylinder	FP00384	1
Swing Over Ram Seal Kit	FP00679	1

*Further parts break downs can be found in following drawings

FC748E Main Ram Assy
 FC748E Hopper Assy
 FC748E Hopper Door Assy
 FC748E Swinger Ram Assy
 FC748E Electrical Drawing

HEAD OFFICE - NSW

15 – 17 Beaumont Rd
 Mt Kuring-gai NSW, 2080
 P: 61 2 9457 8044
 F: 61 2 9457 9205

QUEENSLAND

Unit 1/35 Sodium St
 Narangba, QLD, 4504
 P: 61 7 3888 8988
 F: 61 7 3888 8999

VICTORIA

2/28 Titan Drive
 Carrum Downs, VIC, 3201
 P: 61 3 8787 5844
 F: 61 3 8787 5855

WESTERN AUSTRALIA

10 Industry Street
 Malaga, WA, 6090
 P: 61 8 9248 4811
 F: 61 8 9248 3511

email sales@flowcrete.com.au

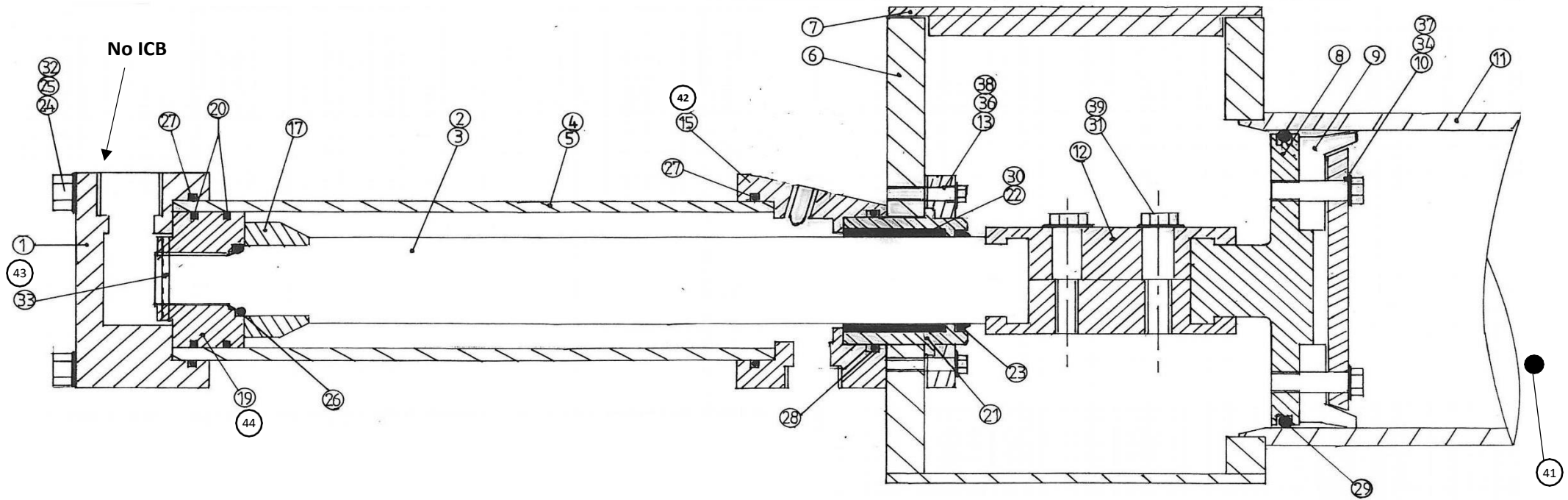

ITEM	DESCRIPTION	QTY	PART #	ITEM	DESCRIPTION	QTY	PART #
1	END CAP	1	FM00253	24	TIE RODS	14	FM01139E
2	PISTON ROD - MASTER	1	FM01137	25	NUTS - M20	14	FP00087
3	PISTON ROD - SLAVE	1	FM01138	26	O-RING B.S.218 90D	2	FP02393/1
4	HYDRAULIC CYL - MASTER	1	FM01141	27	O-RING B.S.240 90D	4	FP00008
5	HYDRAULIC CYL - SLAVE	1	FM01142	28	O-RING B.S.33790D	2	FP01080
6	WATER BOX	1	FM01025	29	O-RING B.S.439 90D	2	FP00846
7	WATER BOX COVER	1	FM00553	30	BRONZE BUSH	2	FP00175
8	CONCRETE PISTON	2	FM01036	31	BOLT ½" UNF x 2 ½" H.T.	4	FP00093
9	CONCRETE PISTON SEAL	2	FP00040	32	SPRING WASHER 20mm	8	FP00138
10	CONCRETE PISTON PLATE	2	FM01037	33	SELLOC PIN "x 2 ½"	2	FP00150
11	CONCRETE CYLINDER	2	FM01140	34	BOLT ¾" UNF x 1 ½"	8	FP00078
12	COUPLING	2	FM00103	35	CAP SCREW UNF x 2 ½"	2	FP01081
13	GLD. HSG. CLAMP PLATE	2	FM01045	36	BOLT M12x30 H.T.	8	FP00706
15	GLD END CAP - SLAVE	1	FM01052	37	SPRING WASHER ⅜"	8	FP00135
17	IMPULSE COLLAR	1	FM00177E	38	SPRING WASER M12	8	FP00136/1
19	HYDRAULIC PISTON	1	FM00213	39	SPRING WASHER ½"	4	FP00136/1
20	PISTON RINGS	4	FP00011	41	REDUCER 7-6	2	FM01030
21	GLAND HOUSING	2	FM01050	42	GLAND END CAP E	1	FM01052/1
22	GLAND PACKING	2	FP00045	43	END CAP E	1	FM00253/1
23	WIPER SEAL	2	FP00031	44	HYD. PISTON E	1	FM00213/E

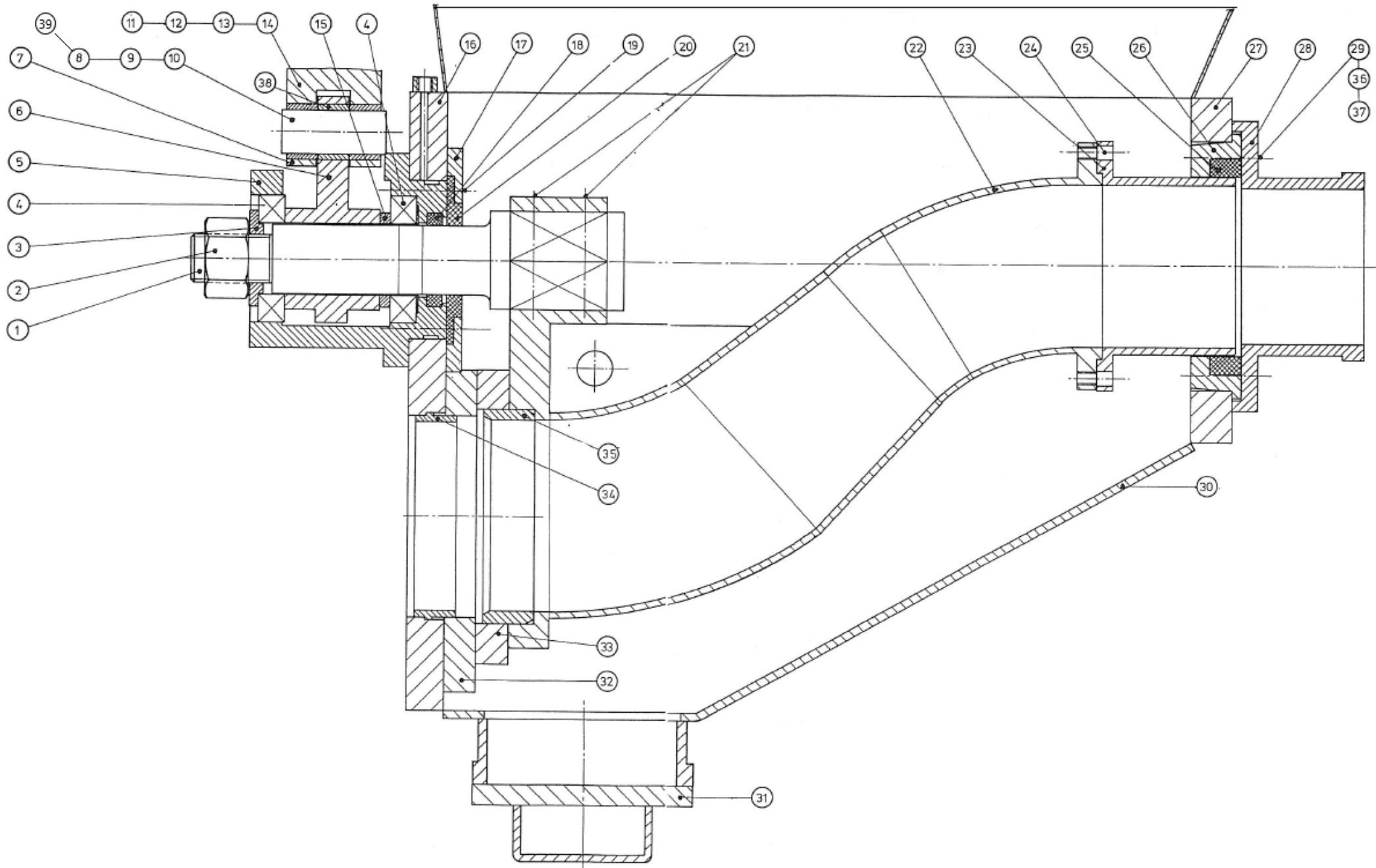

HOPPER ASSY DRAWING

HOPPER ASSEMBLY PARTS LISTING

ITEM #	DESCRIPTION	QTY	PART #
1	SPLINE SHAFT	1	FM00436
2	NUT 1. ½"	1	FP00070
3	WASHER	1	FM00455
4	BEARING	2	FP00357
5	BEARING HOUSING	1	FM00437
6	MINOR LINK	1	FM00454
7	HARD BUSH	2	FP00180
8	GREASE NIPPLE	2	FP00197
9	CIRCLIP	4	FP00117
10	PIN	1	FM01108
11	SWINGER RAM	1	FP00384
12	HARD BUSH	2	FP00356
13	PIN	1	FM00465
14	CLEVIS	1	FM00466
15	SPACER	1	FM00456
16	HOPPER PLATE	1	FM01132
17	SEAL CLAMP PLATE	1	FM00441
18	SEAL	1	FP00358
19	BOLT 5/8" UNF x 2.1/2"	4	FP00102
20	LINTEX SEAL	1	FP00354

ITEM #	DESCRIPTION	QTY	PART #
21	BOLT 5/8" UNF x 2.1/2"	4	FP00109
22	S PIECE	1	FM01158
23	CHROMED OUTLET	1	FM00502
24	BOLT 3/8" UNF x 1"	6	FP00075
25	OUTLET SEAL	1	FP00082
26	OUTLET SEAL HOUSING	1	FM00062
27	HOPPER OUTLET PLATE	1	FM01133
28	OUTLET	1	FM00033
29	BOLT ½" UNF x 2. ½"	4	FP00093
30	HOPPER	1	FM01104
31	HOPPER DOOR – SEE LISTING NEXT PAGE		
32	WEAR PLATE	1	FM00439T
33	WEAR RING	1	FM00115T
34	ANTI CHIP RING	2	FM00113
35	WEAR RING LOCATOR	1	FM00448
36	NUT ½"	4	FP000125
37	WASHER ½ "	4	FP000125
38	HARD BUSH	2	FP00376
39	WASHER SHIM 1" X 1 1/2" X 28G	2	FP01351

31: Hopper Door Assembly

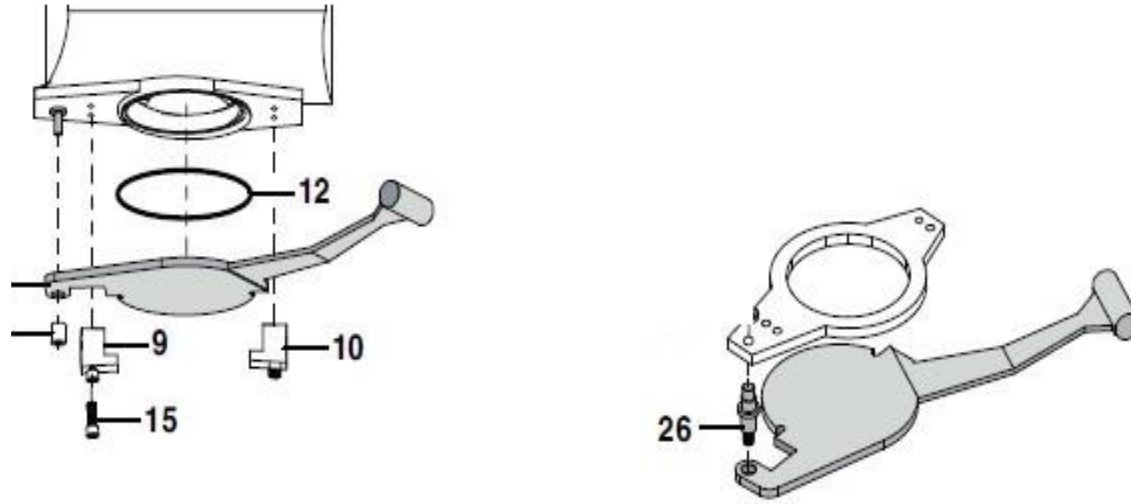

HOPPER DOOR ASSY			
ITEM	DESCRIPTION	QTY	PART #
12	O RING	1	JRB74412
4	GATE FOR HOPPER	1	JJ012104
13	DU BUSH	1	JJLFB2530
9	WEDGE – L	1	JJ012109
10	WEDGE – R	1	JJ012110
15	WRENCH BOLT	4	JJBW16045DZ
26	HINGE BOLT	1	JJ01211106

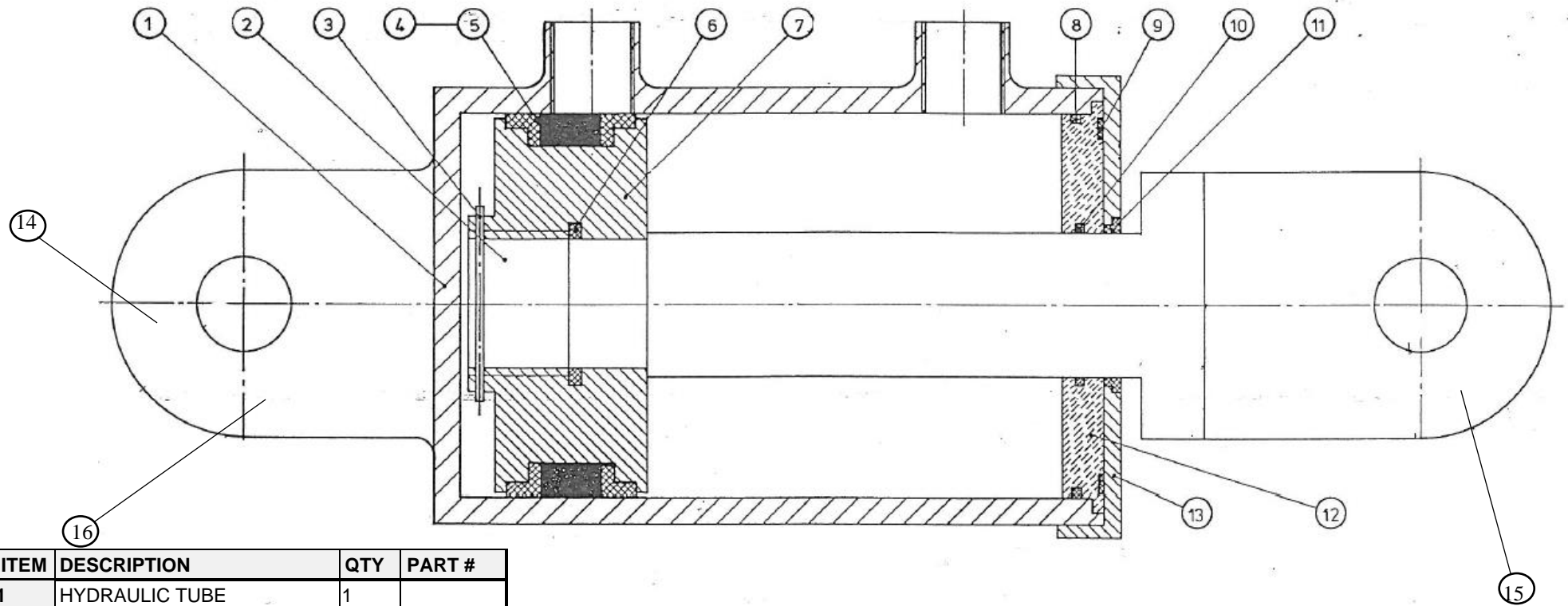

ITEM	DESCRIPTION	QTY	PART #
1	HYDRAULIC TUBE	1	
2	PISTON ROD	1	
3	NYLOC LOCK NUT	1	
4	DOUBLE ACTING SEAL	1	
5	WEAR RING	2	
6	PISTON SPIGOT "O" RING	1	
7	PISTON	1	
8	"O" RING BS 334 & BACK UP BS 334	1	
9	GLAND SEAL	1	
10	ROD RING	1	
11	WIPER SEAL	1	
12	ALUMINIUM GLAND	1	
13	GLAND CAPNUT	1	
14	CLEVIS	1	FM00466
15	PIN	1	FM00465
16	PIN	1	FM01108
N/A	CIRCLIPS FOR PINS	4	FP00117
N/A	SEAL KIT	1	FP00679
N/A	REPLACEMENT ROD	1	FP01637

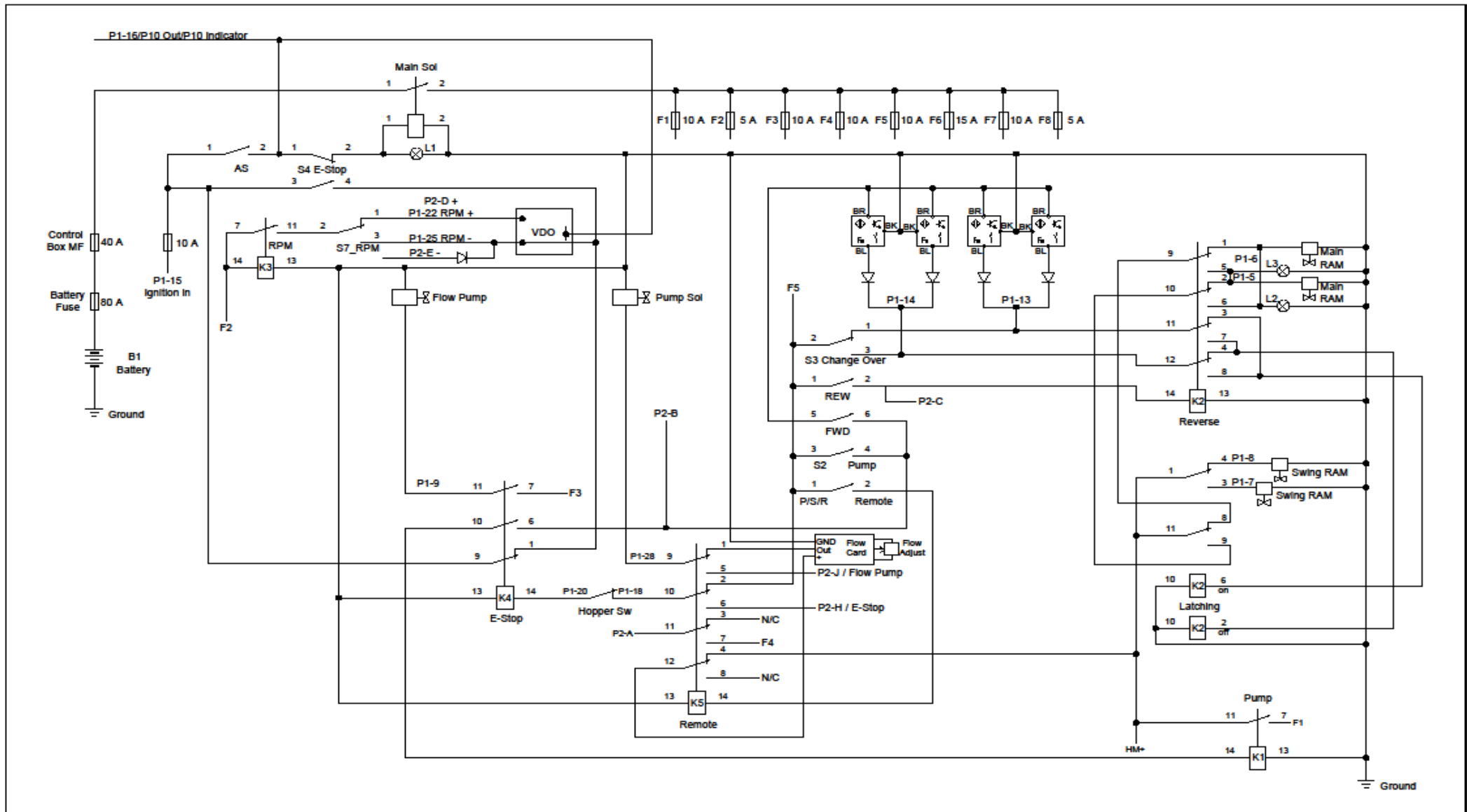

Single Line Diagram

DED BY: DOA: CHECKED BY: SCALE: NTS	DESIGNED BY: CHIEF ELECTRICAL ENGINEER DATE: 12/02/19 DRG. NO: [2019-4-17] RD
--	--

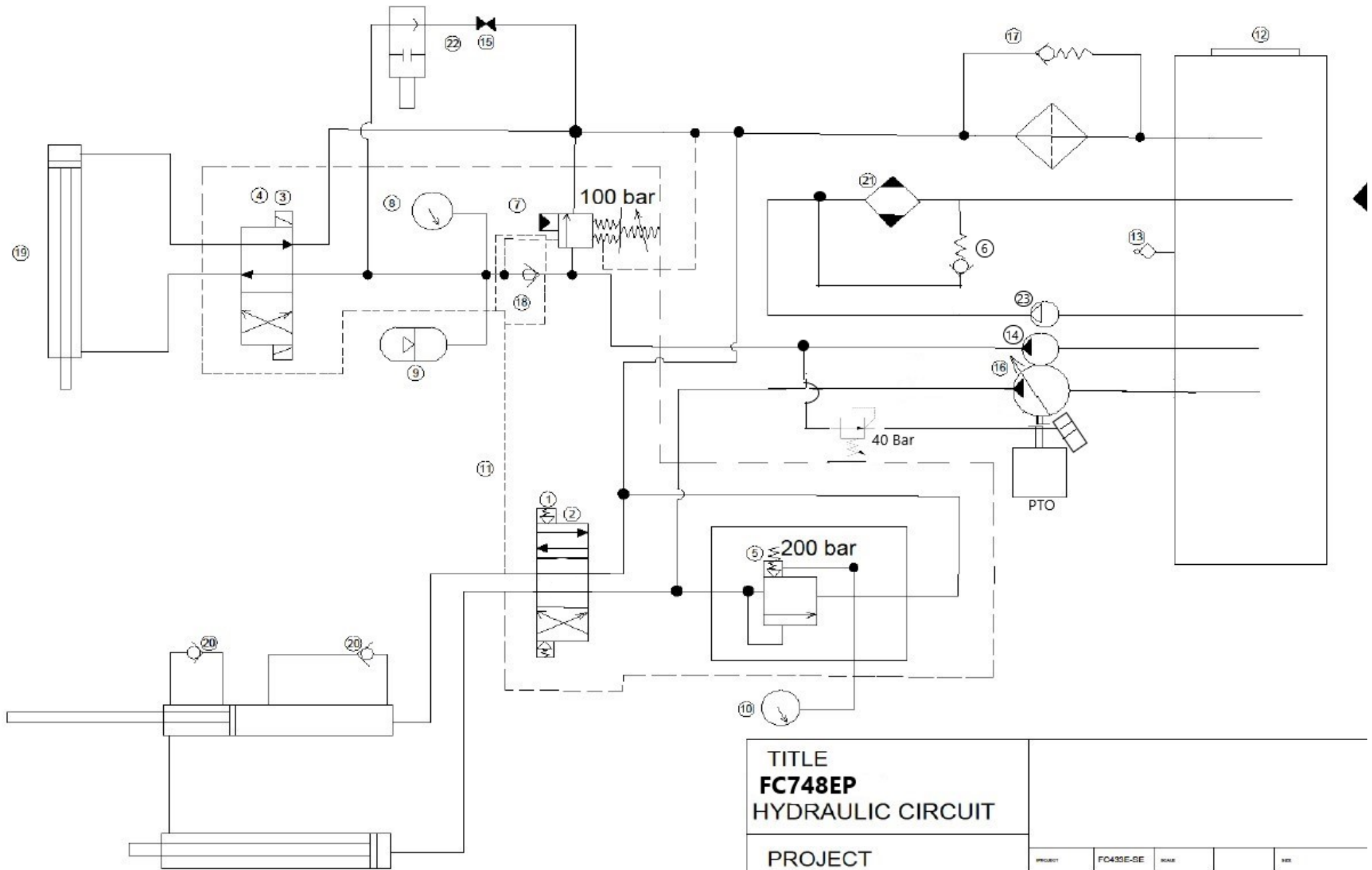

TITLE
FC748EP
 HYDRAULIC CIRCUIT

PROJECT

PROJECT	FC435E-SE	SCALE		REV
DRAWN	1/06/2016	CHECKED		DRAWING NO
APPROVED		DRAWN		FCP913

Hydraulic Circuit Drawing - See next page for parts listing

FC748EP Hydraulic Circuit – Parts Listing

Item #	Description	Part Number
1	MAIN PUMPING COIL	FP02423/1
2	DIRECTIONAL CONROL VALVE	FP02902
3	SWINGER RAM COIL	FP02903/2
4	DIRECTIONAL CONROL VALVE	FP02903
5	MAIN PRESSURE RELIEF VALVE	FP02904
6	3/4" CHECK VALVE	FP01089
7	ACCUMULATOR UNLOADER VALVE	FP02905
8	ACCUMULATOR PRESSURE GAUGE	FP00247
9	ACCUMULATOR	FP00433
10	MAIN PRESSURE GAUGE	FP00592
11	HYDRAULIC MANIFOLD BLOCK	FM00549/2
12	OIL TANK SIGHT LEVEL GAUGE	FP00432
13	OIL TANK FILLER / BREATHER	FP01714
14	ACCUMULATOR OIL PUMP	FP00461
15	3/4 BALL VALVE FOR DUMP	FP02828
16	MAIN OIL PUMP	FP00972/1
17	RETURN FILTER	FP01282
18	ACCUMULATOR CHECK VALVE	(IN BUILT)
19	SWINGER RAM	FP00384
20	1/4" CHECK VALVE	FP00826
21	OIL COOLER	FP01180
22	ACCUMULATOR DUMP VALVE	FP02481/1
23	GEAR PUMP	FP02838

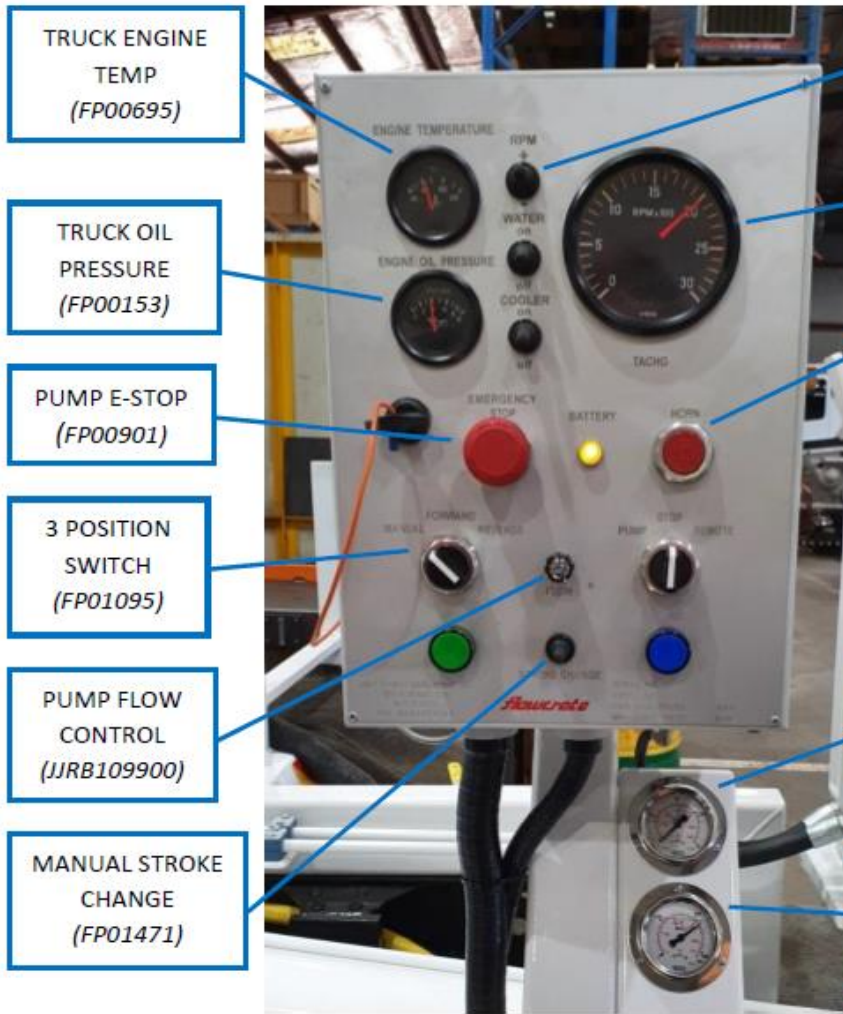

TYPICAL LAYOUT OF 24V FC748EP HYDRAULIC MANIFOLD

DUMP SOLENOID VALVE (FP02481/1)
COIL (JJRB99902)

MAIN PUMPING COIL (FP02423/1)

SWINGER RAM COIL (FP02903/2)

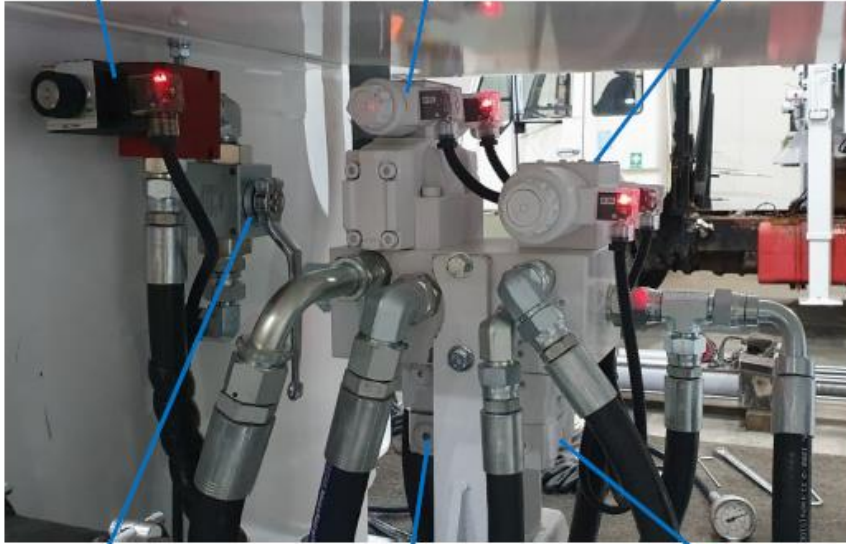

BALL VALVE FOR ACCUMULATOR DUMP (FP02828)

MAIN PRESSURE RELIEF VALVE (FP02904)

ACCUMULATOR PRESSURE UNLOADER VALVE (FP02905)



HYDRAULIC OIL COOLER (FP01180)

PRESSURE REDUCING VALVE (FP02960)

ACCUMULATOR (FP00433)
BLADDER (FP00403)

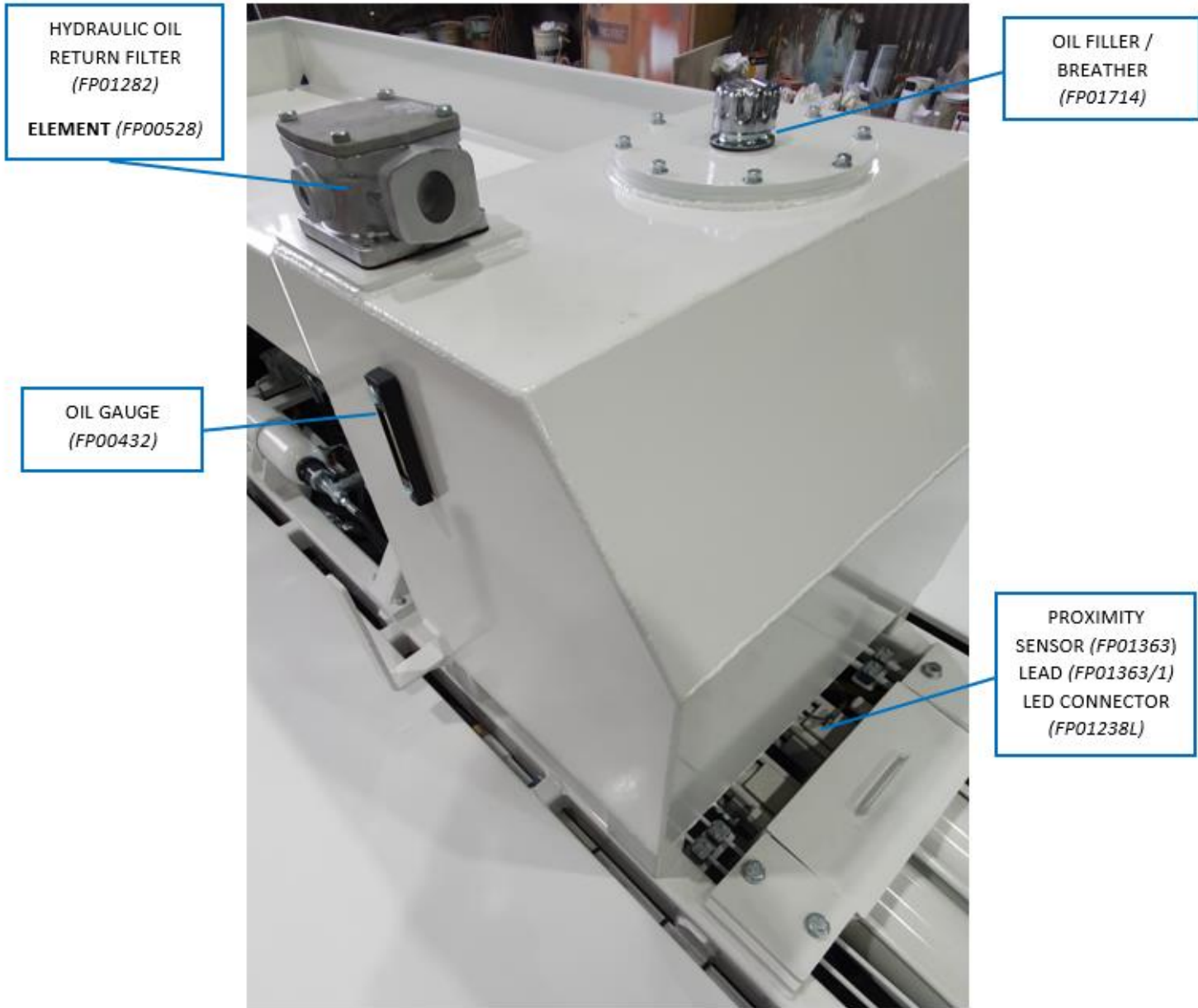

FC748EP OIL TANK & PROXIMITY SENSOR PARTS